

# SUBMINIATURE Switch Modules

# E61-E63 Series

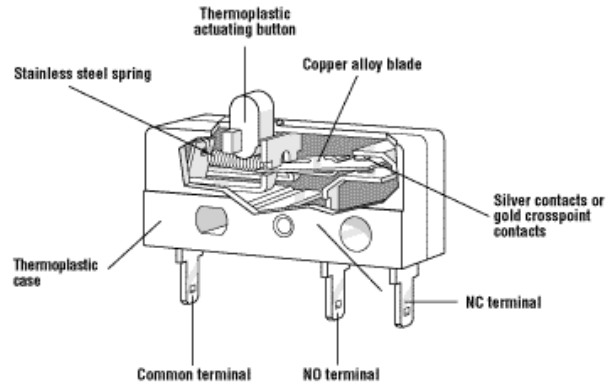

## Features

- 3 Contact Ratings
- Long life coil spring mechanism
- Choice of actuator
- Four terminal types
- RoHS compliant

Electrical Ratings and Operating Life		
Switch Series	According to UL 1054	
	Nominal Load	Electrical Life at Rated Load
E61	5A 125/250 VAC	6000
E62	10.1A 125/250 VAC; 1/4HP 125VAC	6000
E63	0.1A 125VAC	6000

## Technical Specifications

**Temperature Rating:** -40°C to 85°C

**Flammability Rating** UL94HB

**Mounting:** Recommended screw: #2-56 round head  
 Recommended torque: 2 inch lbs. max

**UL File Number:** E23301

Specifications subject to change

## Material Specifications

**Case:** Thermoplastic

**Actuating Button:** Thermoplastic Acetal

**Terminal:** Silver Plated Commercial Bronze

**Moving Blade:** Beryllium Copper

**Spring:** Stainless Steel

**Contacts:** E61, E62: Fine Silver  
 E63: Gold Crosspoint

**Auxiliary Actuator:** Cold Rolled Steel (Nickel-Plated)



SUBMINIATURE Switch Modules

# E61-E63 Series

Dimensions inches

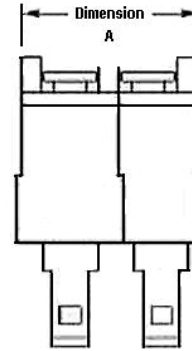
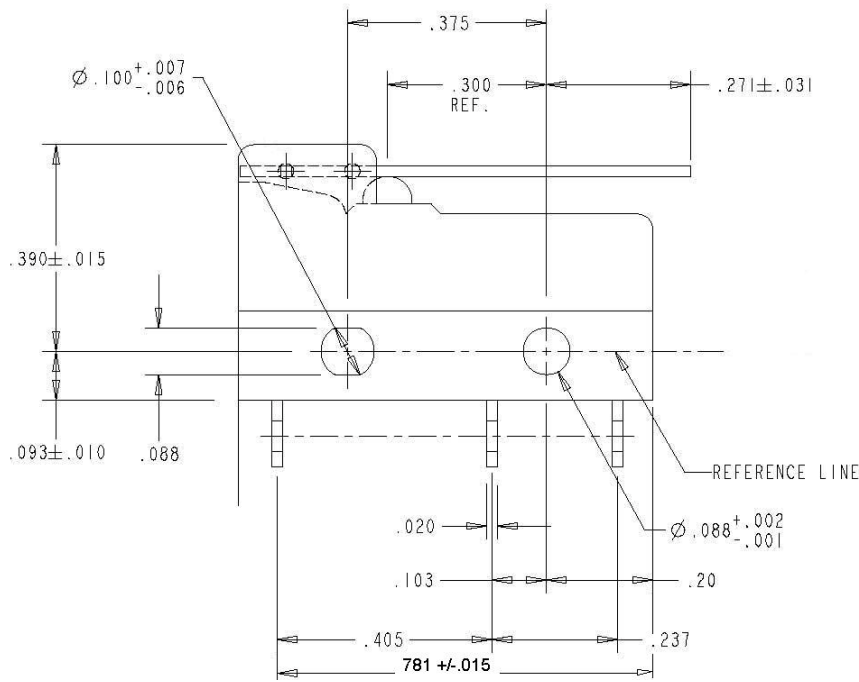

A Dimension
$.470 \pm 0.020$ (11.934 $\pm$ 0.51)
$0.672 \pm 0.020$ (17.07 $\pm$ 0.51)
$0.875 \pm 0.020$ (22.23 $\pm$ 0.51)
$1.066 \pm 0.020$ (27.58 $\pm$ 0.51)

PCB Terminal Footprint

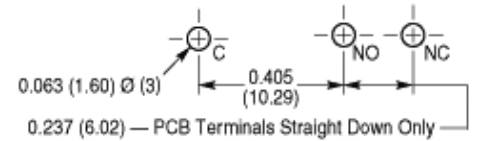

Actuators inches (mm)

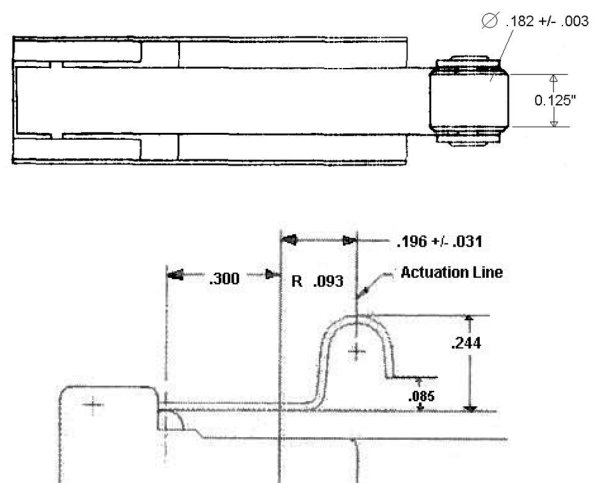
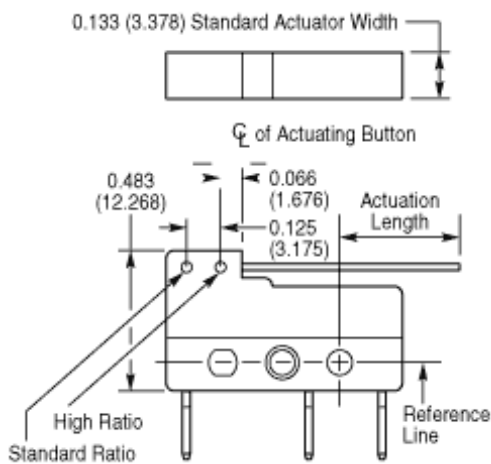

SUBMINIATURE Switch Modules

# E61-E63 Series

**Terminals:**

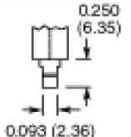
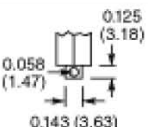
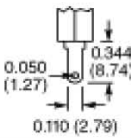
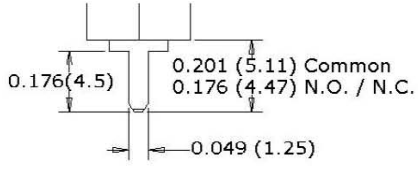
Terminal Type	Dimensions	Actuator Position	Part Number Suffix (with straight lever)			
			2PDT	3PDT	4PDT	5PDT
QC (Quick Connect) 0.093" (2.36)**		Standard Ratio	-02HM	-03HM	-04HM	-05HM
		High Ratio	-52HM	-53HM	-54HM	-55HM
Short Solder 0.143" x 0.125" (3.63mm x 3.18mm)		Standard Ratio	-12HM	-13HM	-14HM	-15HM
		High Ratio	-62HM	-63HM	-64HM	-65HM
QC (Quick Connect) 0.110" (2.794mm)***		Standard Ratio	-32HM	-33HM	-34HM	-35HM
		High Ratio	-82HM	-83HM	-84HM	-85HM
PCB 0.049" x 0.176" (1.25mm x 4.47mm)		Standard Ratio	Consult Factory			
		High Ratio	Consult Factory			

Consult factory for switch part numbers if ordering pcb terminals

**Terminal Mating Connectors:**

\*\* 0.093" QC terminals mate with AMP part number 60432-1

\*\*\* 0.110" QC terminals mate with AMP part number 42068-1

**Switch Characteristics**

- Consult factory for switch availability and characteristics.

**Ordering Information**

1. Select the contact rating prefix you need (E61-E63).
2. Combine the prefix with the corresponding terminal configuration. For example part number E63-02HM will provide you with a gold crosspoint subminiature switch module with 0.093" QC terminals and a straight lever with a 0.396" actuation length.

**Contact**

Call, fax or visit our Website for more information.

**ZF Electronics Corporation**  
 11200 88th Avenue  
 Pleasant Prairie, WI 53158

Phone: 262.942.6500  
 Web: [www.cherrycorp.com](http://www.cherrycorp.com)  
 Email: [cep\\_sales@zf.com](mailto:cep_sales@zf.com)  
 Fax: 262.942.6566

The manufacturer accepts no liability for errors or non-availability, and reserves the right to change specifications without prior notice.

Technical data relates to product specifications only. Features may differ from those described. Only drawings combined with product specifications shall be deemed binding.

© 2007 ZF Electronics

