

Datasheet – MPEG Video/Audio Codec Modules – Standard Version

System-On-Chip (SOC) Technologies

Table of Contents

- 1. Overview of SOC SoM Modules**
 - 1.1 Overview of SOC SoMs
 - 1.2 Product Code for the SOC SoMs
 - 1.3 Overview of SOC Codec Modules
 - 1.4 Product Code for SOC Codec Modules
- 2. Connecting the Module to a User PCB**
- 3. Overview of SOC Standard Codec Modules**
- 4. The H.264 (and MPEG-2) HD Encoder Modules**
 - 4.1 Pin Assignments and Pin Voltages
 - 4.2 Signal Formats
 - 4.2.1 Video Clock Signal (Input)
 - 4.2.2 Video Data Signals (Input)
 - 4.2.3 Audio Data Signals (Input)
 - 4.2.4 TS Signals (Output)
 - 4.2.5 Encoder Control Signals (Input and Output)
 - 4.3 Power Rails of SoM-X-A200T
 - 4.4 Power Requirement and Supply Currents
- 5. The H.264 (and MPEG-2) HD Decoder Modules**
 - 5.1 Pin Assignments and Pin Voltages
 - 5.2 Signal Formats
 - 5.2.1 Clock Signal (Output)
 - 5.2.2 Video Data Signals (Output)
 - 5.2.3 Audio Data Signals (Output)
 - 5.2.4 TS Signals (Input)
 - 5.2.5 Decoder Control Signals (Input and Output)
 - 5.3 Power Rails of SoM-X-A200T
 - 5.4 Power Requirement and Supply Current

6. The H.264 4K@30 Encoder Modules

- 6.1 Pin Assignments and Pin Voltages
- 6.2 Signal Formats
 - 6.2.1 Clock Signals (Input, Output)
 - 6.2.2 Video Data Signals (Input)
 - 6.2.3 Audio Data Signals (Input)
 - 6.2.4 TS Signals (Output)
 - 6.2.5 Encoder Control Signals (Input and Output)
- 6.3 Power Rails of SoM-X-Z7045
- 6.4 Power Requirement and Supply Current

7. The H.264 4K@30 Decoder Modules

- 7.1 Pin Assignments and Pin Voltages
- 7.2 Signal Formats
 - 7.2.1 Video Clock Signal (Input)
 - 7.2.2 Video Data Signals (Output)
 - 7.2.3 Audio Data Signals (Output)
 - 7.2.4 TS Signals (Input)
 - 7.2.5 Decoder Control Signals (Input and Output)
- 7.3 Power Rails of SoM-X-Z7045
- 7.4 Power Requirement and Supply Current

8. The H.264 4K@60 Encoder Modules

- 8.1 Pin Assignments and Pin Voltages
- 8.2 Signal Formats
 - 8.2.1 Clock Signals (Input, Output)
 - 8.2.2 Video Data Signals (Input)
 - 8.2.3 Audio Data Signals (Input)
 - 8.2.4 TS Signals (Output)
 - 8.2.5 Encoder Control Signals (Input and Output)
- 8.3 Power Rails of SoM-I-SX660
- 8.4 Power Requirement and Supply Current

9. The H.264 4K@60 Decoder Modules

- 9.1 Pin Assignments and Pin Voltages
- 9.2 Signal Formats
 - 9.2.1 Video Clock Signal (Input)
 - 9.2.2 Video Data Signals (Output)
 - 9.2.3 Audio Data Signals (Output)
 - 9.2.4 TS Signals (Input)

9.2.5 Decoder Control Signals (Input and Output)**9.3 Power Rails of SoM-I-SX660****9.4 Power Requirement and Supply Current****10. The H.265 HD Encoder Modules****10.1 Pin Assignments and Pin Voltages****10.2 Signal Formats****10.2.1 Clock Signal (Input)****10.2.2 Video Data Signals (Input)****10.2.3 Audio Data Signals (Input)****10.2.4 TS Signals (Output)****10.2.5 Encoder Control Signals (Input and Output)****10.3 Power Rails of SoM-X-Z7045****10.4 Power Requirement and Supply Current****11. The H.265 HD Decoder Modules****11.1 Pin Assignments and Pin Voltages****11.2 Signal Formats****11.2.1 Clock Signal (Input)****11.2.2 Video Data Signals (Output)****11.2.3 Audio Data Signals (Output)****11.2.4 TS Signals (Input)****11.2.5 Decoder Control Signals (Input and Output)****11.3 Power Rails of SoM-X-Z7045****11.4 Power Requirement and Supply Current****12. The H.265 4K@30 Encoder Modules****12.1 Pin Assignments and Pin Voltages****12.2 Signal Formats****12.2.1 Clock Signals (Input, Output)****12.2.2 Video Data Signals (Input)****12.2.3 Audio Data Signals (Input)****12.2.4 TS Signals (Output)****12.2.5 Encoder Control Signals (Input and Output)****12.3 Power Rails of SoM-X-Z7045****12.4 Power Requirement and Supply Current****13. The H.265 4K@30 Decoder Modules****13.1 Pin Assignments and Pin Voltages****13.2 Signal Formats****13.2.1 Clock Signals (Input, Output)**

- 13.2.2 Video Data Signals (Output)
- 13.2.3 Audio Data Signals (Output)
- 13.2.4 TS Signals (Input)
- 13.2.5 Decoder Control Signals (Input and Output)
- 13.3 Power Rails of SoM-X-Z7045
- 13.4 Power Requirement and Supply Current

14. The H.265 4K@60 Encoder Modules

- 14.1 Pin Assignments and Pin Voltages
- 14.2 Signal Formats
 - 14.2.1 Clock Signals (Input, Output)
 - 14.2.2 Video Data Signals (Input)
 - 14.2.3 Audio Data Signals (Input)
 - 14.2.4 TS Signals (Output)
 - 14.2.5 Encoder Control Signals (Input and Output)
- 14.3 Power Rails of SoM-I-SX660
- 14.4 Power Requirement and Supply Current

15. The H.265 4K@60 Decoder Modules

- 15.1 Pin Assignments and Pin Voltages
- 15.2 Signal Formats
 - 15.2.1 Clock Signals (Input, Output)
 - 15.2.2 Video Data Signals (Output)
 - 15.2.3 Audio Data Signals (Output)
 - 15.2.4 TS Signals (Input)
 - 15.2.5 Decoder Control Signals (Input and Output)
- 15.3 Power Rails of SoM-I-SX660
- 15.4 Power Requirement and Supply Current

16. The H.264-to-MPEG2 Transcoder Modules

- 16.1 Pin Assignments and Pin Voltages
- 16.2 Signal Formats
 - 16.2.1 Clock Signal (Input)
 - 16.2.2 Input TS stream Signals (Input)
 - 16.2.3 Output TS stream Signals (Output)
- 16.3 Power Rails of SoM-X-A200T
- 16.4 Power Requirement and Supply Currents

17. The MPEG2-to-H.264 Transcoder Modules

18. The H.264-to-H.265 Transcoder Modules

By request

19. Carrier Board References

16.1 VTR-S1000 Board

16.2 VTR-4000C Board

16.3 VoIP-4000 Board

20. Ordering Information

21. Contact Information

22. Document Versions

Appendix-A SOC Standard Codec Modules

Appendix-B SoM-X-A200T Edge Connector Schematics

Appendix-C SoM-X-Z35/45 Edge Connector Schematics

Appendix-D SoM-I-A660SX Edge Connector Schematics

1. Overview of SOC SoM Modules

1.1 Overview of SOC SoMs

The SOC SoMs (System-On-Module) are small circuit boards with FPGA, DDRs, Flash memory, and clocks in one module to support FPGA-based systems. Table-1 lists the current SOC SoMs, with product code and the FPGA chip on each of the modules. A module can be configured into an application SoM by using the applicable firmware. The module is connected to a user PCB through a standard DDR3 SODIMM connector. Customers can order the blank SoMs from SOC and use their own firmware to make SoM products. Datasheet, application notes, and reference designs are provided in separated documents. This datasheet, however, details the SOC MPEG codec modules based on the SOC codec IP cores and the SoMs.

Table-1 SOC SoMs – Product Code and the FPGA chip on the module

| Item # | SOM Product Code | FPGA Chip on the Module | FPGA Part Number |
|--------|------------------|-------------------------|------------------|
| 1 | SoM-X-SLX150 | Spartan-6 XC6SLX150 | |
| 2 | SoM-X-A200T | Artix-7 XC7A200T | |
| 3 | SoM-X-Z7035 | Zynq-7 XC7Z7035 | |
| 4 | SoM-X-Z7045 | Zynq-7 XC7Z7045 | |
| 5 | SoM-I-SX660 | Arria-10 SX066 | |

Fig. 1 shows a photo of the modules. Figs. 2-5 show the dimensions of SoM-X-SLX150, SoM-X-A200T, SoM-X-Z7035, and SoM-I-SX660 respectively. The SoM-X-Z7045 is identical to the SoM-X-Z7035, except the FPGA chip.



Fig. 1 SOC SoM modules

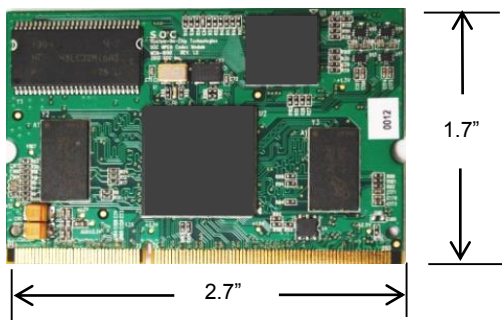

Fig. 2. Dimension of SoM-X-SLX150

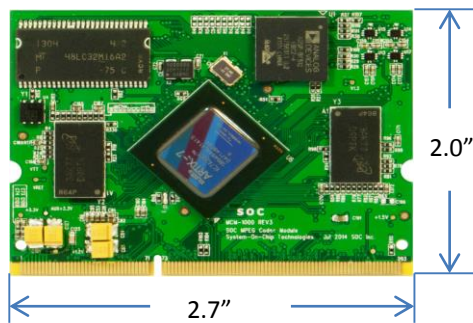

Fig. 3. Dimension of SoM-X-A200T

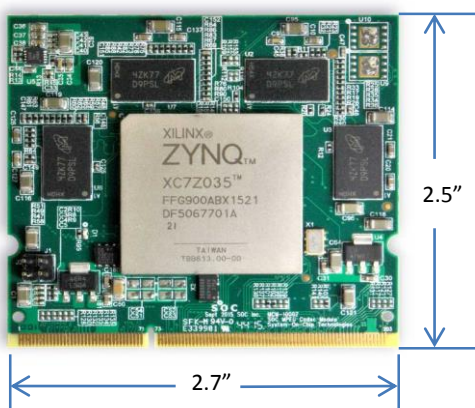

Fig. 4. Dimension of SoM-X-Z7035

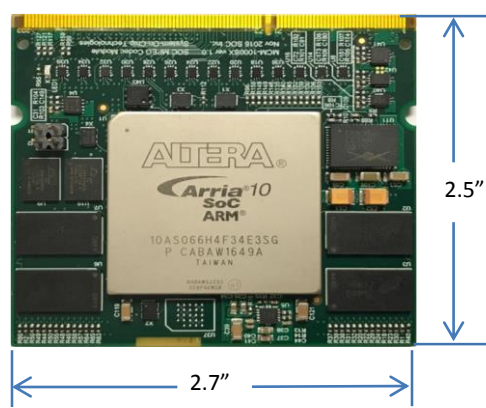

Fig. 5. Dimension of SoM-I-SX660

1.2 Product Code for the SOC SoMs

The SOC SoM product code provides the information of the FPGA chip on the module and the temperature ranges. Fig. 6 shows the product code convention for the SOC SoMs.

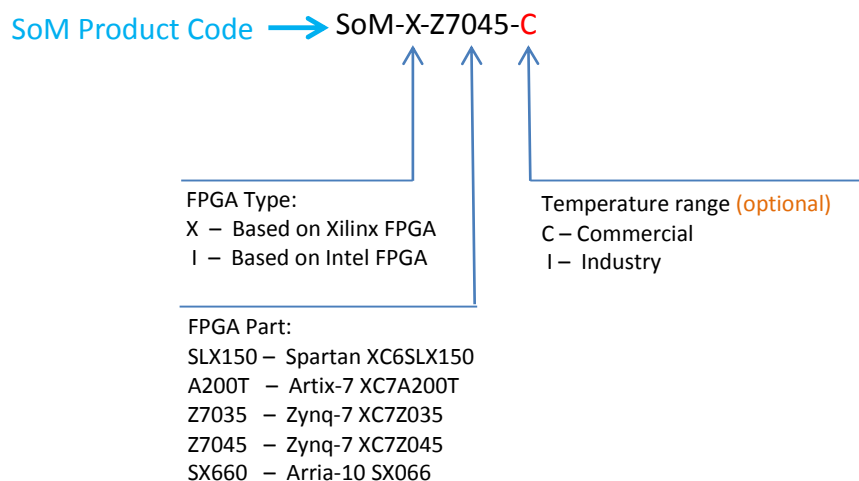

Fig. 6. The SOC SoM product code format

1.3 Overview of SOC Codec Modules

SOC configures the SoMs into MPEG codec modules using the SOC codec IP cores, for video/audio compression, decompression, and transcoding functions. Table-2 lists the SoMs and the resolution capacities when they are configured into codec modules. The product code for the SOC codec modules are discussed in following Section 1.4.

Table-2 SOC Codec modules – SoM Product Code, the FPGA chip on the module, and resolution capabilities

| | SoM Product Code | FPGA Chip on the Module | Codec module Resolution Capacity |
|---|------------------------------|-----------------------------|---|
| 1 | SoM-X-SLX150 | Spartan-6 XC6SLX150 | H.264 or MPEG-2 HD up to 1080@30 <i>(MOQ of 100pcs required)</i> |
| 2 | SoM-X-A200T | Artix-7 XC7A200T | H.264 or MPEG-2 HD, 1080@30 and 1080@60 |
| 3 | SoM-X-Z7035 (or SoM-X-Z7045) | Zynq-7 XC7Z035 (or XC7Z045) | H.264 4k@30 |
| 4 | SoM-X-Z7045 | Zynq-7 XC7Z045 | H.265 1080@60 and 4k@30 |
| 5 | SoM-I-SX660 | Arria-10 SX066 | H.264 4k@60 and 8k@30 H.265 4k@60 |

1.4 Product Code for SOC Codec Modules

The SOC codec modules are pre-configured SoMs using the SOC codec IP cores (encoder, decoders, and transcoders, etc). Once a SoM is configured, it becomes a functional module according to the IP core used to configure it. SOC offers a series of MPEG codec modules as standard products. Fig. 7 shows the product code format for the SOC MPEG codec modules.

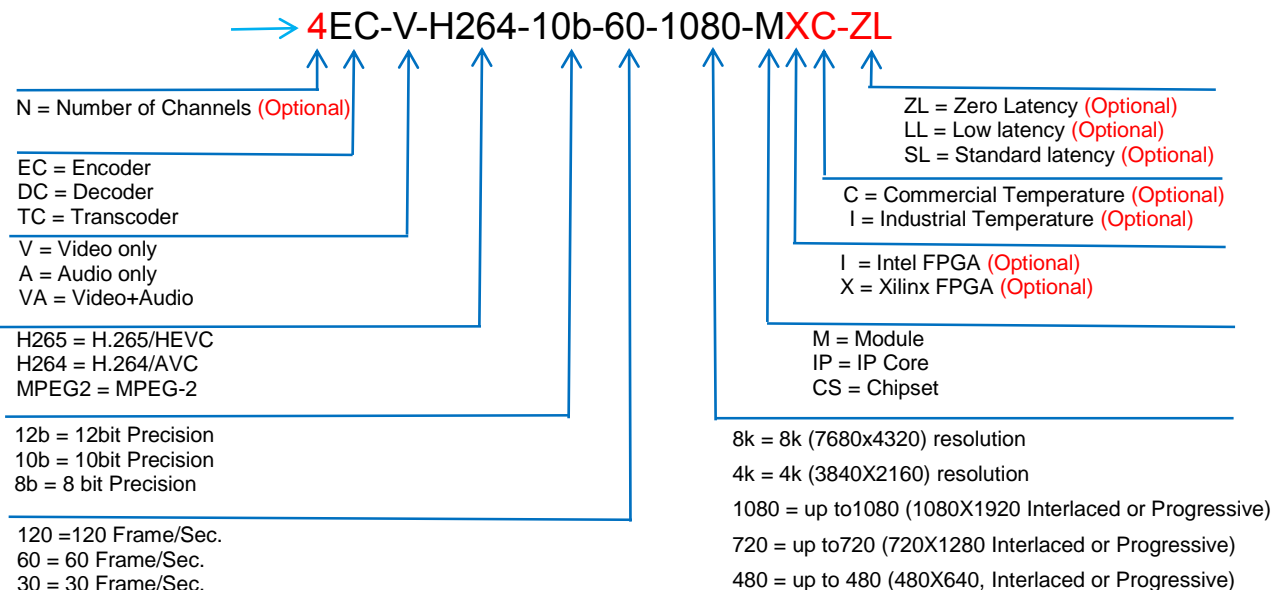

Fig. 7. The SOC Codec Module product code format

As shown in Fig. 7, the product code of the SOC codec module reflects the functionality (Encoder, Decode, or Transcoder, etc.) and the technical specification of the module (MPEG standard, resolution, frame rate, and precision). It has the same format for the SOC MPEG codec IP cores and chipsets, as SOC offers IP core licensing and chipsets as separated product lines. There are optional fields in the product code, which can be included or ignored. These optional fields include:

1. The number of channels
2. FPGA type, Intel or Xilinx
3. Temperature, commercial or industrial
4. Latency, Zero, Standard, or lower latency.

It is noted that the information of the SoM used for the codec module is not reflected in the Codec Module product code. This is intended to reduce the length of the product code. However, the product code of the SoM that is used for a specific Codec Module can be added together with the Codec Module product code to identify the SoM on which a given Codec Module is based. For example:

SoM-X-Z7045-C

EC-V-H264-10b-60-1080-M-ZL

Would mean a Codec Module made from the SoM that has a Zynq-7045 FPGA of commercial temperature, and configured into a Video Encoder module with the specifications of H.264, 10bit, 1080@60 resolution, and zero latency.

2. Connecting the Module to a User PCB

The SoM modules have identical edge pins that are compatible with standard DDR3 SODIMM 204 pin connector. The following off-the-shelf DDR3 SODIMM connectors can be used to connect the SOC SoMs or the codec modules onto a user PCB:

1. MM80-204B1-1
2. MM80-204B1-1E
3. AS0A621-U2SN-7F
4. AS0A621-H2S6-7H

Fig. 8 shows a photo of a standard 204 pin DDR3 SODIMM PCB connector. Refer to the datasheet of the connector used for the physical dimension and PCB design requirements.



Fig. 8 A photo of the standard 204 pin DDR3 SODIMM connector

3. Overview SOC Standard Codec Modules

The above described SoMs: the **SoM-X-SLX150** (based on Spatran-6 FPGA), **SoM-X-A200T** (based on Artix-7 FPGA), **SoM-X-Z7035/SoM-X-Z7045**(based on Zynq-7 FPGAs), and **SoM-I-SX660** (based on Intel Arria-10 FPGAs) can be configured into different products by downloading the desired firmware. At SOC, we produce encoder, decoder, transcoder, and multi-channel encoder or decoder SoMs for video compression functions, by configuring the SoMs using the **SOC MPEG Codec IP** cores.

The standard encoder modules: H.265, H.264, and MPEG-2, take raw video and audio as input and output TS streams, via the edge pins of the modules, as shown in Fig. 9. The standard decoder modules: H.265, H.264, and MPEG-2, take TS stream as inputs and output decoded video and audio, via the edge pins of the modules, as shown in Fig. 10. There are also control signal pins, to allow the user control of the encoder or decoder.

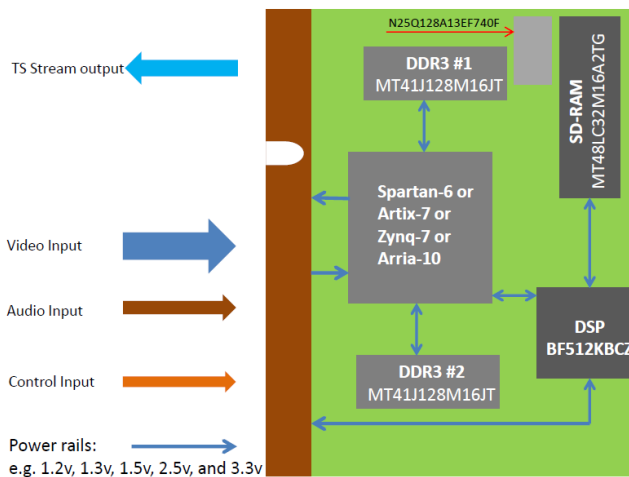

Fig. 9 SOC Standard encoder modules (H.265, H.264, or MPEG-2)

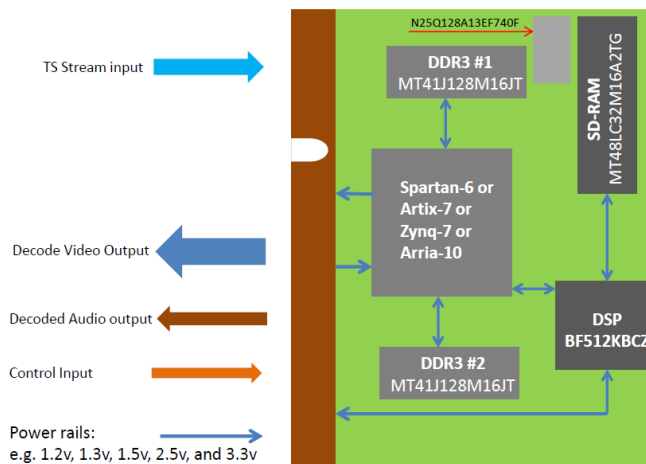

Fig. 10 SOC Standard decoder modules (H.265, H.264, or MPEG-2)

Appendix-A provides the details of the Standard Codec Modules, including the product tables which list the product codes along with the specifications. Customers can order the modules according the specifications required by using the corresponding product code.

The pin assignments, pin voltages, and signal formats for standard encoder modules, decoder modules, and transcoder modules are detailed in this Datasheet respectively.

It should be noted that not all of the modules listed in Appendix-A are discussed in this Datasheet. Pin assignments and electrical properties for the modules that are not provided in this document will be provided on demand basis.

SOC also offers customized modules according to customer requirements, such as Transcoder modules, Multi-channel encoder or decoder modules, and modules with non-standard I/Os. For details, contact SOC sales at: sales@soctechnologies.com

One of the popular extended versions of the standard codec modules is the –NET version which integrates the SOC low latency network stack (UDP/IP over Ethernet) into the encoder or decoder module. The pin assignments, pin voltages, and signal formats for the –NET version encoder and decoder modules are detailed in the document:

[Datasheet – MPEG Video/Audio Codec Modules –NET Version](#)

(Left Empty here intentionally)

4. The H.264 (and MPEG-2) HD Encoder Modules

4.1 Pin Assignments and Pin Voltages

The HD (1080@30 and 1080@60) encoder modules for H.264 or MPEG-2 have the same pin assignments and electrical properties. The SoM (module hardware) for H.264 or MPEG-2 HD resolution encoder uses the SoM-X-A200T (the Artix-7 A200T FPGA).

Note: The H.264 (or MPEG-2) HD 1080@30 Encoder can use the SoM-X-SLX150 module. But, it is a legacy product which is offered only for special orders (with volume). The Datasheet for the H.264 HD 1080@30 Encoder on the SoM-X-SLX150 module is available on request.

This Section provides the pin assignments and electrical properties for H.264 or MPEG-2 HD encoder module which is based on the SoM-X-A200T. Table-3 lists the pin assignments and the pin voltages.

The schematics of SoM-X-A200T edge connector are attached in Appendix-B of this document, which shows the pin numbers for data, clock, control, and power. It should be noted that the encoder module uses only some of the edge pins, and not all of the edge pins are used.

Table-3 also lists the FPGA pin numbers that are connected to the edge pins assigned to the encoder. The Artix-7 datasheet provides further information regarding the properties of these pins, and can be used as a reference for use PCB design when the SoM-X-A200T is used.

Table 3: HD Encoder Module (based on SoM-X-A200T) Pin Assignment and Pin Voltages

| Description | SoM-X-A200T Edge Connector Pin # | Direction | FPGA Pin # | Voltage | IO Standard |
|-----------------------|----------------------------------|-----------|------------|---------|-------------|
| Video Clock | 105 | Input | AB15 | 3.3V | LVC MOS33 |
| Video Horizontal Sync | 133 | Input | M18 | 1.5V | LVC MOS15 |
| Video Vertical Sync | 113 | Input | AB17 | 3.3V | LVC MOS33 |
| Video Display Enable | 67 | Input | J15 | 1.5V | LVC MOS15 |
| Video Data Luma[0] | 135 | Input | N20 | 1.5V | LVC MOS15 |
| Video Data Luma[1] | 137 | Input | N19 | 1.5V | LVC MOS15 |
| Video Data Luma[2] | 116 | Input | G15 | 1.5V | LVC MOS15 |
| Video Data Luma[3] | 118 | Input | H15 | 1.5V | LVC MOS15 |
| Video Data Luma[4] | 124 | Input | G16 | 1.5V | LVC MOS15 |
| Video Data Luma[5] | 126 | Input | J16 | 1.5V | LVC MOS15 |
| Video Data Luma[6] | 128 | Input | J17 | 1.5V | LVC MOS15 |
| Video Data Luma[7] | 130 | Input | H17 | 1.5V | LVC MOS15 |
| Video Data Luma[8] | 132 | Input | G18 | 1.5V | LVC MOS15 |
| Video Data Luma[9] | 134 | Input | N18 | 1.5V | LVC MOS15 |
| Video Data Chroma[0] | 143 | Input | L18 | 1.5V | LVC MOS15 |
| Video Data Chroma[1] | 145 | Input | M20 | 1.5V | LVC MOS15 |
| Video Data Chroma[2] | 147 | Input | L19 | 1.5V | LVC MOS15 |
| Video Data Chroma[3] | 149 | Input | L20 | 1.5V | LVC MOS15 |
| Video Data Chroma[4] | 151 | Input | K18 | 1.5V | LVC MOS15 |

| | | | | | |
|-------------------------------|-----|--------|-----|------|-----------|
| Video Data Chroma[5] | 153 | Input | K19 | 1.5V | LVC MOS15 |
| Video Data Chroma[6] | 155 | Input | J20 | 1.5V | LVC MOS15 |
| Video Data Chroma[7] | 157 | Input | J21 | 1.5V | LVC MOS15 |
| Video Data Chroma[8] | 159 | Input | J19 | 1.5V | LVC MOS15 |
| Video Data Chroma[9] | 161 | Input | H19 | 1.5V | LVC MOS15 |
| SPDIF Audio | 27 | Input | G13 | 1.5V | LVC MOS15 |
| Transport Stream Buffer Ready | 29 | Input | H13 | 1.5V | LVC MOS15 |
| Transport Stream Clock | 31 | Output | H14 | 1.5V | LVC MOS15 |
| Transport Stream Data Valid | 33 | Output | J14 | 1.5V | LVC MOS15 |
| Transport Stream Data[0] | 152 | Output | B20 | 3.3V | LVC MOS33 |
| Transport Stream Data[1] | 154 | Output | C19 | 3.3V | LVC MOS33 |
| Transport Stream Data[2] | 158 | Output | A19 | 3.3V | LVC MOS33 |
| Transport Stream Data[3] | 160 | Output | A18 | 3.3V | LVC MOS33 |
| Transport Stream Data[4] | 162 | Output | T18 | 3.3V | LVC MOS33 |
| Transport Stream Data[5] | 164 | Output | T20 | 3.3V | LVC MOS33 |
| Transport Stream Data[6] | 166 | Output | T19 | 3.3V | LVC MOS33 |
| Transport Stream Data[7] | 156 | Output | A20 | 3.3V | LVC MOS33 |
| Uart_tx | 90 | Output | U18 | 3.3V | LVC MOS33 |
| Uart_rx | 88 | Input | Y12 | 3.3V | LVC MOS33 |

4.2 Signal Formats

4.2.1 Video Clock Signal (Input)

The **Video Clock** signal has two functions: (1) It is the clock for the input video data, and (2) it is the clock that drives the encoder engine.

The **Video Clock** signal usually comes from the video input interface chip, such as HDMI or SDI. It is the clock for the input video data. It is also used for driving the encoder engine. A local clock source (e.g. oscillator) is required to drive the video input interface chip. The frequency varies according to the resolution of the video input. The following are the clock frequencies for standard video resolutions.

1. 27MHz, for SD resolution
2. 74.25MHz, for 720@60 and 1080@30
3. 148.5MHz, for 1080@60

4.2.2 Video Data Signals (Input)

The input to the encoder module (H.264 or MPEG-2) is raw video data in YUV format (4:2:2 or 4:2:0), with 10 input lines: **Video Data Luma[0]** to **Video Data Luma[9]**, for Luma; and 10 input lines: **Video Data Chroma[0]** to **Video Data Chroma[9]**, for the Chroma. The precision can be either 8-bit or 10-bit. When 8-bit precision is used, **Video Data Luma[0]**, **Video Data Luma[1]**, **Video Data Chroma[0]**, and **Video Data Chroma[1]** are zeros. All of the Video Data signals are single-ended.

In addition to the video Luma and Chroma data signals, the **Video Horizontal Sync** and **Video Vertical Sync** signals are required for frame synchronization. A **Video Clock** coming from the video interface chip (refer to Section 4.2.1 for the clock frequencies) is required to provide the timing for the parallel input of luma, chroma, as well as for

the **Video Horizontal Sync** and **Video Vertical Sync** signals. The **Video Display Enable** signal is a part of the **Video Horizontal Sync** and **Video Vertical Sync** system, where high signal indicates active video pixels. For example, an HDMI input interface chip will output the **Display Enable signal** at high, when active pixels are being sent out. The video data are sampled at the rising edge of the clock. The clock rates will correspond to the resolution and frame rate, as discussed in Section 4.2.1.

4.2.3 Audio Data Signals (Input)

Input line **SPDIF Audio** is for PCM audio input, in **SPDIF** frames. An **SPDIF** transmitter is required to send the PCM data to the encoder module. Refer to the **SPDIF** protocol documents for details.

4.2.4 TS stream Signals (Output)

The output of the encoder module is MPEG Transport Stream (TS), which is sent out from the module by 8 parallel lines: **Transport Stream Data[0]** to **Transport Stream Data[7]**; along with the Transport Stream output data clock **Transport Stream Clock**. The frequency of the Transport Stream Data clock is 27MHz.

Transport Stream Buffer Ready and **Transport Stream Data Valid** are the signals to inform the user side to take over the signals.

4.2.5 Encoder Control Signals (Input and Output)

Uart_rx and **Uart_tx** are the API pins for controlling the operations of the encoder. **Uart_rx** receives the command from an external control device. **Uart_tx** sends the encoder information to the control device. Refer to the **Uart** standard for details of **Uart** operations. The SOC API User Manual provides the register map for the API control. Refer to the [Encoder API User Manual](#) for more details.

4.3 Power Rails of SoM-X-A200T

Table-4 lists the power and ground pins. Refer to Appendix-B for the pins of power and ground on the edge connector of the SoM-X-A200T module.

Table-4: SoM-X-A200T Power and Ground Pins

| SoM-X-A200T Connector Pin | Voltage |
|---------------------------------|---------|
| 1,3,5,7,9,11,13,15 | 3.3V |
| 10,12,14,16 | 1.2V |
| 22,24,26,28,30,32 | 1.5V |
| 189,191,193,195,197,199 | 2.5V |
| 188,190,192,194 | 1.3V |
| 43,45,47,49,51,53,55,57 | 1.0V |
| 2,4,6,8,18,20,34,36,42,44,62,72 | Ground |
| 17,35,37,39,41,71 | Ground |
| 73,75,129 | Ground |
| 74 | Ground |
| 175,177,185,187,203 | Ground |
| 184,186,200,202,204 | Ground |

4.4 Power Requirement and Supply Current

The total power, at operation, required by a given encoder module ranges from 2 to 5 watts, depending on the resolution and frame rate. Since the total power is delivered over 6 power rails, each individual power rail delivers only a portion of the total power. However, the power is not evenly distributed among the rails. Table-5 provides a power estimation for each rail for the carrier board PCB design purpose.

Table-5: Power supply estimation for the carrier board PCB design

| Power Rail | Current (A) | Power (W) |
|------------|-------------|-----------|
| 3.3V | 0.23 | 0.76 |
| 2.5V | 0.62 | 1.55 |
| 1.5V | 0.78 | 1.16 |
| 1.3V | 0.23 | 0.30 |
| 1.2V | 0.47 | 0.57 |
| 1.0V | 2.12 | 2.12 |

Since the encoder module normally shares the power supplies with the carrier board (user PCB). The power design should be considered for both. SOC licenses the schematics of carrier boards, such as the VTR-S1000 and VTR-4000C discussed in Section 19 of this document. The reference designs provide not only the power system design and clock distributions, but also the I/O port designs, such as SDI, HDMI, Mini-USB, etc. Please contact SOC sale at: sales@soctechnologies.com for design licensing details.

4.5 Booting Sequence and Booting Time

The module design has considered the booting sequence of the FPGA on the module. Therefore, there is no booting sequence requirement by the module for carrier board designs, i.e. the power rails can be supplied to the module at the same time or at any sequence. Once all of the power rails are ready, the module will start to boot. The booting time is less than 2 seconds.

(Left Empty here intentionally)

5. The H.264 (and MPEG-2) HD Decoder Modules

5.1 Pin Assignments and Pin Voltages

The modules of H.264 HD (1080@30 and 1080@60) decoders and the MPEG-2 HD decoder have the same pin assignment. The module for HD resolution decoding uses the SoM-X-A200T (with the Artix-7 A200T FPGA which is the same as the one used for the HD Encoder).

Note: The H.264 HD 1080@30 Decoder can use the SoM-X-SLX150 module. But, it is a legacy product which is offered only for special orders (with volume). The Datasheet for the H.264 HD 1080@30 Decoder on the SoM-X-SLX150 module is available on request.

This section details the pin assignments and pin voltages for the HD decoder (H.264 and MPEG-2) modules. Table-6 shows the pin assignments and the pin voltages.

The schematics of SoM-X-A200T edge connector are attached in Appendix-B of this document. Appendix-B shows the pin numbers for data, clock, control, and power, which are connected to the FPGA (Artix-7 XC7A200T). It should be noted that the decoder module uses only some of the available edge pins that are connected to the FPGA (some of the pins are not used).

It should also be noted that the HD encoder and decoder pin assignments are symmetrical, i.e. the video input pins on the encoder module become the video output pins on the decoder module.

Table-6: HD Decoder Module (based on SoM-X-A200T) Pin Assignment

| Description | SoM-X-A200T Edge Connector Pin | Direction | FPGA Pin # | Voltage | IO Standard |
|-----------------------|--------------------------------|-----------|------------|---------|-------------|
| Decoder Clock | 80 | Input | R17 | 3.3V | LVCNOS33 |
| Use Decoder Clock | 63 | Input | L14 | 1.5V | LVCNOS15 |
| Video Clock | 105 | Output | AB15 | 3.3V | LVCNOS33 |
| Video Horizontal Sync | 133 | Output | M18 | 1.5V | LVCNOS15 |
| Video Vertical Sync | 113 | Output | AB17 | 3.3V | LVCNOS33 |
| Video Display Enable | 67 | Output | J15 | 1.5V | LVCNOS15 |
| Video Data Luma[0] | 135 | Output | N20 | 1.5V | LVCNOS15 |
| Video Data Luma[1] | 137 | Output | N19 | 1.5V | LVCNOS15 |
| Video Data Luma[2] | 116 | Output | G15 | 1.5V | LVCNOS15 |
| Video Data Luma[3] | 118 | Output | H15 | 1.5V | LVCNOS15 |
| Video Data Luma[4] | 124 | Output | G16 | 1.5V | LVCNOS15 |
| Video Data Luma[5] | 126 | Output | J16 | 1.5V | LVCNOS15 |
| Video Data Luma[6] | 128 | Output | J17 | 1.5V | LVCNOS15 |
| Video Data Luma[7] | 130 | Output | H17 | 1.5V | LVCNOS15 |
| Video Data Luma[8] | 132 | Output | G18 | 1.5V | LVCNOS15 |
| Video Data Luma[9] | 134 | Output | N18 | 1.5V | LVCNOS15 |
| Video Data Chroma[0] | 143 | Output | L18 | 1.5V | LVCNOS15 |
| Video Data Chroma[1] | 145 | Output | M20 | 1.5V | LVCNOS15 |
| Video Data Chroma[2] | 147 | Output | L19 | 1.5V | LVCNOS15 |
| Video Data Chroma[3] | 149 | Output | L20 | 1.5V | LVCNOS15 |
| Video Data Chroma[4] | 151 | Output | K18 | 1.5V | LVCNOS15 |

| | | | | | |
|---|------------|--------|-----|------|-----------|
| Video Data Chroma[5] | 153 | Output | K19 | 1.5V | LVC MOS15 |
| Video Data Chroma[6] | 155 | Output | J20 | 1.5V | LVC MOS15 |
| Video Data Chroma[7] | 157 | Output | J21 | 1.5V | LVC MOS15 |
| Video Data Chroma[8] | 159 | Output | J19 | 1.5V | LVC MOS15 |
| Video Data Chroma[9] | 161 | Output | H19 | 1.5V | LVC MOS15 |
| SPDIF Audio | 27 | Output | G13 | 1.5V | LVC MOS15 |
| Transport Stream Clock (27MHz) | 31 | Input | H14 | 1.5V | LVC MOS33 |
| Transport Stream Data Valid | 33 | Input | J14 | 1.5V | LVC MOS33 |
| Transport Stream Data[0] | 152 | Input | B20 | 3.3V | LVC MOS33 |
| Transport Stream Data[1] | 154 | Input | C19 | 3.3V | LVC MOS33 |
| Transport Stream Data[2] | 158 | Input | A19 | 3.3V | LVC MOS33 |
| Transport Stream Data[3] | 160 | Input | A18 | 3.3V | LVC MOS33 |
| Transport Stream Data[4] | 162 | Input | T18 | 3.3V | LVC MOS33 |
| Transport Stream Data[5] | 164 | Input | T20 | 3.3V | LVC MOS33 |
| Transport Stream Data[6] | 166 | Input | T19 | 3.3V | LVC MOS33 |
| Transport Stream Data[7] | 156 | Input | A20 | 3.3V | LVC MOS33 |
| Uart_tx | 90 | Output | U18 | 3.3V | LVC MOS33 |
| Uart_rx | 88 | Input | Y12 | 3.3V | LVC MOS33 |

5.2 Signal Formats

5.2.1 Clock Signals

When an SDI port on the carrier board is used to send out the decoded video data, the SDI clock should be connected to the **Decoder Clock** and **Use Decoder Clock** should be tied high. This will automatically synchronize the decoder outputs with the SDI interface. Internally generated clock is used if **Use Decoder Clock** is tied low.

The SDI clock frequencies are:

1. 27MHz, for SD resolution
2. 74.25MHz, for 720@60 and 1080@30
3. 148.5MHz, for 1080@60

The **Video Clock** signal is the clock for the video data output by the decoder. The frequency of the **Video clock** is determined by the video resolution, which are:

1. 27MHz, for SD resolution
2. 74.25MHz, for 720@60 and 1080@30
3. 148.5MHz, for 1080@60.

5.2.2 Video Data Signals (Output)

The output of the HD decoder module (H.264 or MPEG-2) is the decoded video data in YUV format (4:2:2 or 4:2:0), with 10 input lines: **Video Data Luma[0]** to **Video Data Luma[9]**, for Luma and 10 lines, and, **Video Data Chroma[0]**

to **Video Data Chroma[9]**, for the Chroma. The precision can be either 8-bit or 10-bit. When 8-bit precision is used, **Video Data Luma[0]**, **Video Data Luma[1]**, **Video Data Chroma[0]**, and **Video Data Chroma[1]** are zeros.

In addition to the video Luma and Chroma data signals, the **Video Horizontal Sync** and **Video Vertical Sync** signals are provided for frame synchronization. A **Video Clock** (refer to Section 5.2.1 for the clock frequencies) is sent out, which provides the timing for the parallel inputs of luma, chroma, as well as the **Video Horizontal Sync** and **Video Vertical Sync** signals. The **Video Display Enable** signal is a part of the **Video Horizontal Sync** and **Video Vertical Sync** system, where high signal indicates active video pixels.

Output data are sampled at the rising edge of the clock. (The clock rates will correspond to the resolution and frame rate, as discussed in Section 5.2.1.)

5.2.3 Audio Data Signals (Output)

Line **SPDIF Audio** is for PCM audio output, in **SPDIF** frames. An **SPDIF** transmitter is included in the module to send the PCM data out via the decoder edge pins. Refer to the **SPDIF** protocol documents for details.

5.2.4 TS Stream Signals (Input)

The input of the decoder module is an MPEG transport stream, which is sent into the module by 8 parallel lines: **Transport Stream Data[0]** to **Transport Stream Data[7]**. **Transport Stream Clock** (27MHz) is the clock for the **Transport Stream Data** lines. The **Transport Stream Data Valid** signal informs the decoder that the input is valid.

5.2.5 Decoder Control Signals (Input and Output)

Uart_rx and **Uart_tx** are the API pins for controlling the operations of the decoder. **Uart_rx** receives the command from an external control device. **Uart_tx** send the decoder information to the control device. Refer to the **Uart** standard for details of **Uart** operations. The SOC API User Manual provides the register map for the API control. Refer to the [Decoder API User Manual](#) for details.

5.3 Power Rails of SoM-X-A200T

The power rails for the HD (H.264 or MPEG-2) decoder module is the same as the ones for the HD encoder module. Refer to Table-2 for the power and ground pins. Also, refer to Appendix-B for the power and ground pins on the edge connector of the SoM-X-A200T module.

5.4 Power Requirement and Supply Current

The total power at operation required by a given decoder ranges from 2 to 4 Watts, depending on the resolution and frame rate. Since the decoder requires less power than the encoder, the power supply for the encoder can be used as a reference for the carrier board PCB designs. It is listed here again for convenience, as Table-7.

Table-7: Power supply estimation for the carrier board PCB design

| Power Rail | Current (A) | Power (W) |
|------------|-------------|-----------|
| 3.3V | 0.23 | 0.76 |
| 2.5V | 0.62 | 1.55 |
| 1.5V | 0.78 | 1.16 |
| 1.3V | 0.23 | 0.30 |
| 1.2V | 0.47 | 0.57 |
| 1.0V | 2.12 | 2.12 |

5.5 Booting Sequence and Booting Time

The module design has considered the booting sequence of the FPGA on the module. Therefore, there is no booting sequence requirement by the module for carrier board designs, i.e. the power rails can be supplied to the module at the same time or at any sequence. Once all of the power rails are supplied, the module will start to boot. The booting time is less than 2 seconds.

(Left Empty here intentionally)

6. The H.264 4k@30 Encoder Modules

6.1 Pin Assignments and Pin Voltages

The SoM-X-Z7035 or SoM-X-Z7045 module is used for H.264 4K@30 resolution. The pin assignment and electrical properties are the same for SoM-X-Z7035 and SoM-X-Z7045.

Table-8 lists the pin assignments and the pin voltages for the 4K@30 encoder modules based on the SoM-X-Z7045 (SoM-X-Z7035 and SoM-X-Z7045 are the same).

The schematics of SoM-X-Z7045 edge connector are attached in Appendix-C of this document, which shows the pin numbers for data, clock, control, and power.

Table-8 also lists the FPGA pin numbers that are connected to the edge pins assigned to the encoder. The Zynq-7000 datasheet provides further information regarding the properties of these pins, and can be used as a reference for user PCB designs that use the SoM-X-Z7045 module.

Table-8: 4K@30 Encoder Module (based on SoM-X-Z7045) Pin Assignment and Pin Voltages

| Description | SoM-X-Z7045 Edge Connector | Direction | FPGA Pin # | Voltage | IO Standard |
|-----------------------|----------------------------|-----------|------------|---------|-------------|
| PS Soft Reset B | 156 | Input | B19 | 3.3V | LVC MOS33 |
| Video Clock 0 | 63 | Input | AC18 | 1.5V | LVC MOS15 |
| Video Clock 1 | 80 | Input | AF15 | 3.3V | LVC MOS33 |
| Video Clock 2 | 144 | Input | AE28 | 3.3V | LVC MOS33 |
| Video Clock 3 | 105 | Input | AG21 | 3.3V | LVC MOS33 |
| Video Horizontal Sync | 133 | Input | W24 | 1.5V | LVC MOS15 |
| Video Vertical Sync | 113 | Input | AF22 | 3.3V | LVC MOS33 |
| Video Display Enable | 67 | Input | AD18 | 1.5V | LVC MOS15 |
| Video Data 0 Luma[0] | 135 | Input | W25 | 1.5V | LVC MOS15 |
| Video Data 0 Luma[1] | 137 | Input | W26 | 1.5V | LVC MOS15 |
| Video Data 0 Luma[2] | 116 | Input | V27 | 1.5V | LVC MOS15 |
| Video Data 0 Luma[3] | 118 | Input | W28 | 1.5V | LVC MOS15 |
| Video Data 0 Luma[4] | 124 | Input | W29 | 1.5V | LVC MOS15 |
| Video Data 0 Luma[5] | 126 | Input | W30 | 1.5V | LVC MOS15 |
| Video Data 0 Luma[6] | 128 | Input | V28 | 1.5V | LVC MOS15 |
| Video Data 0 Luma[7] | 130 | Input | V29 | 1.5V | LVC MOS15 |
| Video Data 0 Luma[8] | 132 | Input | T30 | 1.5V | LVC MOS15 |
| Video Data 0 Luma[9] | 134 | Input | U30 | 1.5V | LVC MOS15 |
| Video Data 1 Luma[0] | 117 | Input | AG22 | 3.3V | LVC MOS33 |
| Video Data 1 Luma[1] | 119 | Input | AH22 | 3.3V | LVC MOS33 |
| Video Data 1 Luma[2] | 121 | Input | AJ21 | 3.3V | LVC MOS33 |
| Video Data 1 Luma[3] | 123 | Input | AK21 | 3.3V | LVC MOS33 |
| Video Data 1 Luma[4] | 125 | Input | AF23 | 3.3V | LVC MOS33 |

| | | | | | |
|------------------------|-----|-------|------|------|-----------|
| Video Data 1 Luma[5] | 127 | Input | AF24 | 3.3V | LVC MOS33 |
| Video Data 1 Luma[6] | 92 | Input | AJ23 | 3.3V | LVC MOS33 |
| Video Data 1 Luma[7] | 94 | Input | AJ24 | 3.3V | LVC MOS33 |
| Video Data 1 Luma[8] | 96 | Input | AG24 | 3.3V | LVC MOS33 |
| Video Data 1 Luma[9] | 98 | Input | AG25 | 3.3V | LVC MOS33 |
| Video Data 2 Luma[0] | 77 | Input | AJ16 | 3.3V | LVC MOS33 |
| Video Data 2 Luma[1] | 79 | Input | AK16 | 3.3V | LVC MOS33 |
| Video Data 2 Luma[2] | 81 | Input | AH17 | 3.3V | LVC MOS33 |
| Video Data 2 Luma[3] | 83 | Input | AH16 | 3.3V | LVC MOS33 |
| Video Data 2 Luma[4] | 85 | Input | AH18 | 3.3V | LVC MOS33 |
| Video Data 2 Luma[5] | 87 | Input | AJ18 | 3.3V | LVC MOS33 |
| Video Data 2 Luma[6] | 78 | Input | AF13 | 3.3V | LVC MOS33 |
| Video Data 2 Luma[7] | 82 | Input | AG15 | 3.3V | LVC MOS33 |
| Video Data 2 Luma[8] | 84 | Input | AG17 | 3.3V | LVC MOS33 |
| Video Data 2 Luma[9] | 86 | Input | AG16 | 3.3V | LVC MOS33 |
| Video Data 3 Luma[0] | 107 | Input | AH21 | 3.3V | LVC MOS33 |
| Video Data 3 Luma[1] | 122 | Input | AH29 | 3.3V | LVC MOS33 |
| Video Data 3 Luma[2] | 115 | Input | AE22 | 3.3V | LVC MOS33 |
| Video Data 3 Luma[3] | 146 | Input | AF28 | 3.3V | LVC MOS33 |
| Video Data 3 Luma[4] | 148 | Input | AF29 | 3.3V | LVC MOS33 |
| Video Data 3 Luma[5] | 150 | Input | AG29 | 3.3V | LVC MOS33 |
| Video Data 3 Luma[6] | 100 | Input | AH23 | 3.3V | LVC MOS33 |
| Video Data 3 Luma[7] | 102 | Input | AH24 | 3.3V | LVC MOS33 |
| Video Data 3 Luma[8] | 104 | Input | AJ25 | 3.3V | LVC MOS33 |
| Video Data 3 Luma[9] | 106 | Input | AK25 | 3.3V | LVC MOS33 |
| Video Data 0 Chroma[0] | 143 | Input | T29 | 1.5V | LVC MOS15 |
| Video Data 0 Chroma[1] | 145 | Input | U29 | 1.5V | LVC MOS15 |
| Video Data 0 Chroma[2] | 147 | Input | R28 | 1.5V | LVC MOS15 |
| Video Data 0 Chroma[3] | 149 | Input | T28 | 1.5V | LVC MOS15 |
| Video Data 0 Chroma[4] | 151 | Input | P30 | 1.5V | LVC MOS15 |
| Video Data 0 Chroma[5] | 153 | Input | R30 | 1.5V | LVC MOS15 |
| Video Data 0 Chroma[6] | 155 | Input | N29 | 1.5V | LVC MOS15 |
| Video Data 0 Chroma[7] | 157 | Input | P29 | 1.5V | LVC MOS15 |
| Video Data 0 Chroma[8] | 159 | Input | N28 | 1.5V | LVC MOS15 |
| Video Data 0 Chroma[9] | 161 | Input | P28 | 1.5V | LVC MOS15 |
| Video Data 1 Chroma[0] | 89 | Input | AK17 | 3.3V | LVC MOS33 |
| Video Data 1 Chroma[1] | 91 | Input | AK18 | 3.3V | LVC MOS33 |
| Video Data 1 Chroma[2] | 93 | Input | AF19 | 3.3V | LVC MOS33 |
| Video Data 1 Chroma[3] | 95 | Input | AG19 | 3.3V | LVC MOS33 |
| Video Data 1 Chroma[4] | 97 | Input | AH19 | 3.3V | LVC MOS33 |
| Video Data 1 Chroma[5] | 99 | Input | AJ19 | 3.3V | LVC MOS33 |
| Video Data 1 Chroma[6] | 101 | Input | AF20 | 3.3V | LVC MOS33 |
| Video Data 1 Chroma[7] | 103 | Input | AG20 | 3.3V | LVC MOS33 |
| Video Data 1 Chroma[8] | 109 | Input | AJ20 | 3.3V | LVC MOS33 |
| Video Data 1 Chroma[9] | 111 | Input | AK20 | 3.3V | LVC MOS33 |
| Video Data 2 Chroma[0] | 38 | Input | AE12 | 3.3V | LVC MOS33 |
| Video Data 2 Chroma[1] | 40 | Input | AF12 | 3.3V | LVC MOS33 |
| Video Data 2 Chroma[2] | 50 | Input | AG12 | 3.3V | LVC MOS33 |

| | | | | | |
|-------------------------|-----|--------|------|------|-----------|
| Video Data 2 Chroma[3] | 52 | Input | AH12 | 3.3V | LVC MOS33 |
| Video Data 2 Chroma[4] | 54 | Input | AH14 | 3.3V | LVC MOS33 |
| Video Data 2 Chroma[5] | 56 | Input | AH13 | 3.3V | LVC MOS33 |
| Video Data 2 Chroma[6] | 58 | Input | AJ14 | 3.3V | LVC MOS33 |
| Video Data 2 Chroma[7] | 60 | Input | AJ13 | 3.3V | LVC MOS33 |
| Video Data 2 Chroma[8] | 59 | Input | AK13 | 3.3V | LVC MOS33 |
| Video Data 2 Chroma[9] | 61 | Input | AK12 | 3.3V | LVC MOS33 |
| Video Data 3 Chroma[0] | 108 | Input | AJ26 | 3.3V | LVC MOS33 |
| Video Data 3 Chroma[1] | 110 | Input | AK26 | 3.3V | LVC MOS33 |
| Video Data 3 Chroma[2] | 112 | Input | AH26 | 3.3V | LVC MOS33 |
| Video Data 3 Chroma[3] | 114 | Input | AH27 | 3.3V | LVC MOS33 |
| Video Data 3 Chroma[4] | 136 | Input | AK27 | 3.3V | LVC MOS33 |
| Video Data 3 Chroma[5] | 138 | Input | AK28 | 3.3V | LVC MOS33 |
| Video Data 3 Chroma[6] | 139 | Input | AJ28 | 3.3V | LVC MOS33 |
| Video Data 3 Chroma[7] | 141 | Input | AJ29 | 3.3V | LVC MOS33 |
| Video Data 3 Chroma[8] | 140 | Input | AJ30 | 3.3V | LVC MOS33 |
| Video Data 3 Chroma[9] | 142 | Input | AK30 | 3.3V | LVC MOS33 |
| SPDIF Audio | 27 | Input | Y20 | 1.5V | LVC MOS15 |
| Transport Stream Buffer | 29 | Input | AA20 | 1.5V | LVC MOS15 |
| Transport Stream Clock | 31 | Output | AA18 | 1.5V | LVC MOS15 |
| Transport Stream Data | 33 | Output | AA19 | 1.5V | LVC MOS15 |
| Transport Stream Data | 152 | Output | AF30 | 3.3V | LVC MOS33 |
| Transport Stream Data | 154 | Output | AG30 | 3.3V | LVC MOS33 |
| Transport Stream Data | 158 | Output | AE30 | 3.3V | LVC MOS33 |
| Transport Stream Data | 160 | Output | AB29 | 3.3V | LVC MOS33 |
| Transport Stream Data | 162 | Output | AB30 | 3.3V | LVC MOS33 |
| Transport Stream Data | 164 | Output | AA27 | 3.3V | LVC MOS33 |
| Transport Stream Data | 166 | Output | AA28 | 3.3V | LVC MOS33 |
| Transport Stream Data | 120 | Output | AH28 | 3.3V | LVC MOS33 |
| Uart_tx | 90 | Output | AK15 | 3.3V | LVC MOS33 |
| Uart_rx | 88 | Input | AJ15 | 3.3V | LVC MOS33 |

6.2 Signal Formats

6.2.1 Clock Signals (Input)

The 4k@30 encoder has 4 input clocks, **Video Clock 0** (pin #63), **Video Clock 1** (pin #80), **Video Clock 2** (pin #144), and **Video Clock 3** (pin #105). These clocks match the four of 3G SDI inputs for one 4k@30 video. The clock rate is 74.25 MHz, and the video data are sampled at dual data rate, at both the rising and falling edges of the clock. However, if one 4k input is used on the carrier board, such as HDMI 1.4/2.0 or 6/12G SDI, only **Video Clock 0** is needed which is also 74.25 MHz, with dual data rate as well.

6.2.2 Video Data Signals (Input)

The input to the encoder module is raw video data in YUV format (4:2:2 or 4:2:0), with 40 input lines: **Video Data 0 Luma[0]** to **Video Data 3 Luma[9]**, for Luma, and, 40 input lines: **Video Data 0 Chroma[0]** to **Video Data 3**

Chroma[9], for the Chroma. The precision is either 8 bits or 10 bits. For 8-bit precision, the Most Significant Luma and Chroma pins (Luma[2] to Luma[9], Chroma[2] to Chroma[9]) are used.

In addition to the video Luma and Chroma data signals, the **Video Horizontal Sync** and **Video Vertical Sync** signals are required for frame synchronization if embedded SAV/EAV are not used. The video clocks (refer to Section 6.2.1) provide the timing for the parallel input of luma, chroma, as well as the **Video Horizontal Sync** and **Video Vertical Sync** signals. The **Video Display Enable** signal is a part of the **Video Horizontal Sync** and **Video Vertical Sync** system, where high signal indicates active video pixels. For example, an HDMI input interface chip will output the **Video Display Enable** signal at high, when active pixels are being sent out.

The video data are sampled at the rising edge of the clock. The clock rates will correspond to the resolution and frame rate, as discussed in Section 6.2.1.

6.2.3 Audio Data Signals (Input)

Input line **SPDIF Audio** is for PCM audio input, in **SPDIF** frames. An **SPDIF** transmitter is required to send the PCM data to the encoder module. Refer to the **SPDIF** protocol documents for details.

6.2.4 TS stream Signals (Output)

The output of the encoder module is MPEG Transport Stream (TS), which is sent out from the module by 8 parallel lines: **Transport Stream Data[0]** to **Transport Stream Data[7]**, along with the Transport Stream output data clock **Transport Stream Clock** (pin # 31). The frequency of the Transport Stream Data clock is 27MHz.

Transport Stream Buffer Ready (pin # 29) and **Transport Stream Data Valid** (pin # 33) are the signals to inform the user side to take over the signals.

6.2.5 Encoder Control Signals (Input and Output)

Uart_rx and **Uart_tx** are the API pins for controlling the operations of the encoder. **Uart_rx** receives the command from an external control device. **Uart_tx** sends the encoder information to the control device. Refer to the **Uart** standard for details of **Uart** operations. The SOC API User Manual provides the register map for the API control. Refer to the [Encoder API User Manual](#) for more details.

An external reset **PS Soft Reset_B** (pin # 156) is available. This pin allows the user to reset the encoder when necessary. A low signal will trigger a reset. The reset signal should be maintained at high or left unconnected when in normal operation mode.

6.3 Power Rails of SoM-X-Z7045

Refer to Appendix-B for the pins of power and ground on the edge connector of the SoM-X-Z7045 module. The power rails are: 1.0V, 1.2V, 1.3V, 1.5V, 2.5V, and 3.3V.

6.4 Power Requirement and Supply Current

The total power, at operation, required by a given encoder module ranges from 3 to 6 watts, depending on the resolution and frame rate. Since the total power is delivered over 6 power rails (1.0v, 1.2v, 1.3v, 1.5v, 2.5v, and 3.3v), each individual power rails deliveries only a portion of the total power. However, the power is not evenly distributed among the rails. Table-9 lists the power estimations for PCB designs. It should be noted that the estimated total power showing in Table-9 is higher than the real power consumption of the module. It should also be noted that the power rails 1.8v and 2.0v are generated on the module, by using some of the input power rails. Carrier board PCB designers need not to consider these two rails.

Table-9: Power estimation for the H.264 4k@30 encoder module

| Power Rail | Current (A) | Power (W) |
|------------|-------------|-----------|
| 3.3V | 0.31 | 1.02 |
| 2.5V | 0.84 | 2.09 |
| 1.5V | 0.60 | 0.90 |
| 1.3V | 0.19 | 0.24 |
| 1.2V | 0.15 | 0.18 |
| 1.0V | 3.60 | 3.60 |

Since the encoder module normally shares the power supplies with the carrier board (user PCB). The power design should be considered for both the module and the carrier board. SOC licenses the schematics of carrier boards. The VTR-4000C discussed in Section 19 of this document is for 4k resolution. The reference design provides not only the power system design, but also the I/O port designs, such as SDI, HDMI, Mini-USB, etc. Contact SOC sale at: sales@soctechnologies.com for design licensing information.

6.5 Booting Sequence and Booting Time

The module design has considered the booting sequence of the FPGA on the module. Therefore, there is no booting sequence requirement by the module for carrier board designs, i.e. the power rails can be supplied to the module at the same time or at any sequence. Once all of the power rails are supplied, the module will start to boot. The booting time is less than 2 seconds.

(Left Empty here intentionally)

7. The H.264 4K@30 Decoder Modules

7.1 Pin Assignments and Pin Voltages

The modules for H.264 4K@30 resolution decoder use the SoM-X-Z7035 or Zynq-7045. This section details the pin assignment and pin voltages for H.264 4K@30 decoder modules based on the SoM-X-Z7045 hardware (the SoM-X-Z7035 is the same).

Table-10 shows the pin assignments and the pin voltages for H.264 4k decoder modules based on the SoM-X-Z7045.

The schematics of SoM-X-Z7045 edge connector are attached in Appendix-C of this document. Appendix-C shows the pin numbers for data, clock, control, and power, which are connected to the FPGA (Zynq-7035 or 7045, which are pin-compatible).

It should be noted that the 4K@30 encoder and decoder pin assignments are symmetrical, i.e. the video input pins on the encoder module become the video output pins on the decoder module.

Table-10: H.264 4K@30 Decoder Module (based on SoM-X-Z7045) Pin Assignment

| Description | SoM-X-Z7045 Edge Connector Pin # | Direction | FPGA Pin # | Voltage | IO Standard |
|-----------------------|----------------------------------|-----------|------------|---------|-------------|
| PS Soft Reset_B | 156 | Input | B19 | 3.3V | LVC MOS33 |
| Decoder Clock | 76 | Input | AE13 | 3.3V | LVC MOS33 |
| Video Clock | 105 | Output | AG21 | 3.3V | LVC MOS33 |
| Video Horizontal Sync | 133 | Output | W24 | 1.5V | LVC MOS15 |
| Video Vertical Sync | 113 | Output | AF22 | 1.5V | LVC MOS33 |
| Video Display Enable | 67 | Output | AD18 | 1.5V | LVC MOS15 |
| Video Data 0 Luma[0] | 135 | Output | W25 | 1.5V | LVC MOS15 |
| Video Data 0 Luma[1] | 137 | Output | W26 | 1.5V | LVC MOS15 |
| Video Data 0 Luma[2] | 116 | Output | V27 | 1.5V | LVC MOS15 |
| Video Data 0 Luma[3] | 118 | Output | W28 | 1.5V | LVC MOS15 |
| Video Data 0 Luma[4] | 124 | Output | W29 | 1.5V | LVC MOS15 |
| Video Data 0 Luma[5] | 126 | Output | W30 | 1.5V | LVC MOS15 |
| Video Data 0 Luma[6] | 128 | Output | V28 | 1.5V | LVC MOS15 |
| Video Data 0 Luma[7] | 130 | Output | V29 | 1.5V | LVC MOS15 |
| Video Data 0 Luma[8] | 132 | Output | T30 | 1.5V | LVC MOS15 |
| Video Data 0 Luma[9] | 134 | Output | U30 | 1.5V | LVC MOS15 |
| Video Data 1 Luma[0] | 117 | Output | AG22 | 3.3v | LVC MOS33 |
| Video Data 1 Luma[1] | 119 | Output | AH22 | 3.3v | LVC MOS33 |
| Video Data 1 Luma[2] | 121 | Output | AJ21 | 3.3V | LVC MOS33 |
| Video Data 1 Luma[3] | 123 | Output | AK21 | 3.3V | LVC MOS33 |
| Video Data 1 Luma[4] | 125 | Output | AF23 | 3.3V | LVC MOS33 |
| Video Data 1 Luma[5] | 127 | Output | AF24 | 3.3V | LVC MOS33 |

| | | | | | |
|------------------------|-----|--------|------|------|-----------|
| Video Data 1 Luma[6] | 92 | Output | AJ23 | 3.3V | LVC MOS33 |
| Video Data 1 Luma[7] | 94 | Output | AJ24 | 3.3V | LVC MOS33 |
| Video Data 1 Luma[8] | 96 | Output | AG24 | 3.3V | LVC MOS33 |
| Video Data 1 Luma[9] | 98 | Output | AG25 | 3.3V | LVC MOS33 |
| Video Data 2 Luma[0] | 77 | Output | AJ16 | 3.3V | LVC MOS33 |
| Video Data 2 Luma[1] | 79 | Output | AK16 | 3.3V | LVC MOS33 |
| Video Data 2 Luma[2] | 81 | Output | AH17 | 3.3V | LVC MOS33 |
| Video Data 2 Luma[3] | 83 | Output | AH16 | 3.3V | LVC MOS33 |
| Video Data 2 Luma[4] | 85 | Output | AH18 | 3.3V | LVC MOS33 |
| Video Data 2 Luma[5] | 87 | Output | AJ18 | 3.3V | LVC MOS33 |
| Video Data 2 Luma[6] | 78 | Output | AF13 | 3.3V | LVC MOS33 |
| Video Data 2 Luma[7] | 82 | Output | AG15 | 3.3V | LVC MOS33 |
| Video Data 2 Luma[8] | 84 | Output | AG17 | 3.3V | LVC MOS33 |
| Video Data 2 Luma[9] | 86 | Output | AG16 | 3.3V | LVC MOS33 |
| Video Data 3 Luma[0] | 107 | Output | AH21 | 3.3V | LVC MOS33 |
| Video Data 3 Luma[1] | 122 | Output | AH29 | 3.3V | LVC MOS33 |
| Video Data 3 Luma[2] | 115 | Output | AE22 | 3.3V | LVC MOS33 |
| Video Data 3 Luma[3] | 146 | Output | AF28 | 3.3V | LVC MOS33 |
| Video Data 3 Luma[4] | 148 | Output | AF29 | 3.3V | LVC MOS33 |
| Video Data 3 Luma[5] | 150 | Output | AG29 | 3.3V | LVC MOS33 |
| Video Data 3 Luma[6] | 100 | Output | AH23 | 3.3V | LVC MOS33 |
| Video Data 3 Luma[7] | 102 | Output | AH24 | 3.3V | LVC MOS33 |
| Video Data 3 Luma[8] | 104 | Output | AJ25 | 3.3V | LVC MOS33 |
| Video Data 3 Luma[9] | 106 | Output | AK25 | 3.3V | LVC MOS33 |
| Video Data 0 Chroma[0] | 143 | Output | T29 | 1.5V | LVC MOS15 |
| Video Data 0 Chroma[1] | 145 | Output | U29 | 1.5V | LVC MOS15 |
| Video Data 0 Chroma[2] | 147 | Output | R28 | 1.5V | LVC MOS15 |
| Video Data 0 Chroma[3] | 149 | Output | T28 | 1.5V | LVC MOS15 |
| Video Data 0 Chroma[4] | 151 | Output | P30 | 1.5V | LVC MOS15 |
| Video Data 0 Chroma[5] | 153 | Output | R30 | 1.5V | LVC MOS15 |
| Video Data 0 Chroma[6] | 155 | Output | N29 | 1.5V | LVC MOS15 |
| Video Data 0 Chroma[7] | 157 | Output | P29 | 1.5V | LVC MOS15 |
| Video Data 0 Chroma[8] | 159 | Output | N28 | 1.5V | LVC MOS15 |
| Video Data 0 Chroma[9] | 161 | Output | P28 | 1.5v | LVC MOS15 |
| Video Data 1 Chroma[0] | 89 | Output | AK17 | 3.3V | LVC MOS33 |
| Video Data 1 Chroma[1] | 91 | Output | AK18 | 3.3V | LVC MOS33 |
| Video Data 1 Chroma[2] | 93 | Output | AF19 | 3.3V | LVC MOS33 |
| Video Data 1 Chroma[3] | 95 | Output | AG19 | 3.3V | LVC MOS33 |
| Video Data 1 Chroma[4] | 97 | Output | AH19 | 3.3V | LVC MOS33 |
| Video Data 1 Chroma[5] | 99 | Output | AJ19 | 3.3V | LVC MOS33 |
| Video Data 1 Chroma[6] | 101 | Output | AF20 | 3.3V | LVC MOS33 |
| Video Data 1 Chroma[7] | 103 | Output | AG20 | 3.3V | LVC MOS33 |
| Video Data 1 Chroma[8] | 109 | Output | AJ20 | 3.3V | LVC MOS33 |

| | | | | | |
|-----------------------------|-----|--------|------|------|-----------|
| Video Data 1 Chroma[9] | 111 | Output | AK20 | 3.3V | LVC MOS33 |
| Video Data 2 Chroma[0] | 38 | Output | AE12 | 3.3V | LVC MOS33 |
| Video Data 2 Chroma[1] | 40 | Output | AF12 | 3.3V | LVC MOS33 |
| Video Data 2 Chroma[2] | 50 | Output | AG12 | 3.3V | LVC MOS33 |
| Video Data 2 Chroma[3] | 52 | Output | AH12 | 3.3V | LVC MOS33 |
| Video Data 2 Chroma[4] | 54 | Output | AH14 | 3.3V | LVC MOS33 |
| Video Data 2 Chroma[5] | 56 | Output | AH13 | 3.3V | LVC MOS33 |
| Video Data 2 Chroma[6] | 58 | Output | AJ14 | 3.3V | LVC MOS33 |
| Video Data 2 Chroma[7] | 60 | Output | AJ13 | 3.3V | LVC MOS33 |
| Video Data 2 Chroma[8] | 59 | Output | AK13 | 3.3V | LVC MOS33 |
| Video Data 2 Chroma[9] | 61 | Output | AK12 | 3.3V | LVC MOS33 |
| Video Data 3 Chroma[0] | 108 | Output | AJ26 | 3.3V | LVC MOS33 |
| Video Data 3 Chroma[1] | 110 | Output | AK26 | 3.3V | LVC MOS33 |
| Video Data 3 Chroma[2] | 112 | Output | AH26 | 3.3V | LVC MOS33 |
| Video Data 3 Chroma[3] | 114 | Output | AH27 | 3.3V | LVC MOS33 |
| Video Data 3 Chroma[4] | 136 | Output | AK27 | 3.3V | LVC MOS33 |
| Video Data 3 Chroma[5] | 138 | Output | AK28 | 3.3V | LVC MOS33 |
| Video Data 3 Chroma[6] | 139 | Output | AJ28 | 3.3V | LVC MOS33 |
| Video Data 3 Chroma[7] | 141 | Output | AJ29 | 3.3V | LVC MOS33 |
| Video Data 3 Chroma[8] | 140 | Output | AJ30 | 3.3V | LVC MOS33 |
| Video Data 3 Chroma[9] | 142 | Output | AK30 | 3.3V | LVC MOS33 |
| SPDIF Audio | 27 | Output | Y20 | 1.5V | LVC MOS15 |
| Transport Stream Clock | 31 | Input | AA18 | 1.5V | LVC MOS15 |
| Transport Stream Data Valid | 33 | input | AA19 | 1.5V | LVC MOS15 |
| Transport Stream Data [0] | 152 | input | AF30 | 3.3V | LVC MOS33 |
| Transport Stream Data [1] | 154 | input | AG30 | 3.3V | LVC MOS33 |
| Transport Stream Data [2] | 158 | input | AE30 | 3.3V | LVC MOS33 |
| Transport Stream Data [3] | 160 | input | AB29 | 3.3V | LVC MOS33 |
| Transport Stream Data [4] | 162 | input | AB30 | 3.3V | LVC MOS33 |
| Transport Stream Data [5] | 164 | input | AA27 | 3.3V | LVC MOS33 |
| Transport Stream Data [6] | 166 | input | AA28 | 3.3V | LVC MOS33 |
| Transport Stream Data [7] | 120 | input | AH28 | 3.3V | LVC MOS33 |
| Uart_tx | 90 | Output | AK15 | 3.3V | LVC MOS33 |
| Uart_rx | 88 | Input | AJ15 | 3.3V | LVC MOS33 |

7.2 Signal Formats

7.2.1 Video Clock Signal (Output)

The Decoder Clock signal is an input clock for driving the decoder engine. When an SDI port on the carrier board is used to send out the decoded video data, the SDI clock can be connected to the Decoder Clock. This will automatically synchronize the decoder outputs with the SDI interface. The SDI clock frequency is 74.25MHz, for 4K@30.

The **Video Clock** signal (pin # 105) is the clock signal that provides the timing for the parallel luma, chroma, as well as the **Video Horizontal Sync** and **Video Vertical Sync** signals. The default is 74.25 MHz for 4K@30.

7.2.2 Video Data Signals (Output)

The output of the H.264 4k@30 decoder module is the decoded video data in YUV format (4:2:2 or 4:2:0), with 40 output lines: **Video Data 0 Luma[0]** to **Video Data 3 Luma[9]**, for Luma, and, 40 lines: **Video Data 0 Chroma[0]** to **Video Data 3 Chroma[9]**, for the Chroma. The precision can be either 8-bit precision or 10-bit precision. For 8-bit precision, the Most Significant Bits of luma and chroma output lines (Luma[2] to Luma[9], Chroma[2] to Chroma[9]) are used.

In addition to the video Luma and Chroma data signals, the **Video Horizontal Sync** and **Video Vertical Sync** signals are provided for frame synchronization. The **Video Display Enable** signal is a part of the **Video Horizontal Sync** and **Video Vertical Sync** system, where high signal indicates active video pixels.

7.2.3 Audio Data Signals (Output)

Line **SPDIF Audio** is for PCM audio output, in **SPDIF** frames. An **SPDIF** transmitter is included in the module to send the PCM data out via the decoder edge pins. Refer to the **SPDIF** protocol documents for details.

7.2.4 Decoder Control Signals (Input and output)

Uart_rx and **Uart_tx** are the API pins for controlling the operations of the decoder. **Uart_rx** receives the command from an external control device. **Uart_tx** send the decoder information to the control device. Refer to the **Uart** standard for details of **Uart** operations. The SOC API User Manual provides the register map for the API control. Refer to the [Decoder API User Manual](#) for details.

7.3 Power Rails of SoM-X-Z7045

The power rails for H.264 4K@30 decoder are the same as the H.264 4k@30 encoder. Refer to Appendix-C for the pins of power and ground on the edge connector of the SoM-X-Z7045 module.

7.4 Power Requirement and Supply Current

The total power, at operation, required by a given encoder module ranges from 3 to 5 watts, depending on the resolution and frame rate. Since the total power is delivered over 6 power rails (1.0v, 1.2v, 1.3v, 1.5v, 2.5v, and 3.3v), each individual power rails deliveries only a portion of the total power. However, the power is not evenly distributed among the rails. Table-11 lists the power estimations for PCB designs. It should be noted that the power rails 1.8v and 2.0v are generated on the module using the input power rails. PCB designers for the carrier boards do not need to consider these two rails.

Since the decoder module normally shares the power supplies with the carrier board (user PCB). The power design should be considered for both. SOC licenses the schematics of carrier boards. The VTR-4000C, discussed in Section 19 of this document, is for 4k resolution. The reference designs not only provide the power system design, but also the I/O port designs, such as SDI, HDMI, Mini-USB, etc. Please contact SOC sale at: sales@soctechnologies.com for further details.

Table-11: Power estimation for the H.264 4k@30 decoder module

| Power Rail | Current (A) | Power (W) |
|------------|-------------|-----------|
| 3.3V | 0.31 | 1.02 |
| 2.5V | 0.84 | 2.09 |
| 1.5V | 0.60 | 0.90 |
| 1.3V | 0.19 | 0.24 |
| 1.2V | 0.15 | 0.18 |
| 1.0V | 3.60 | 3.60 |

7.5 Booting Sequence and Booting Time

The module design has considered the booting sequence of the FPGA on the module. Therefore, there is no booting sequence requirement by the module for carrier board designs, i.e. the power rails can be supplied to the module at the same time or at any sequence. Once all of the power rails are supplied, the module will start to boot. The booting time is less than 2 seconds.

(Left Empty here intentionally)

8. The H.264 4k@60 Encoder Modules

8.1 Pin Assignments and Pin Voltages

The SoM-I-SX660 is used for the 4K@60 resolution encoder module. Table-10 lists the pin assignments and the pin voltages for the 4K@60 encoder modules based on the SoM-I-SX660.

The schematics of SoM-I-SX660 edge connector are attached in Appendix-D of this document, which shows the pin numbers for data, clock, control, and power.

Table-12 also lists the FPGA pin numbers that are connected to the edge pins assigned to the encoder. The Arria-10 datasheet provides further information regarding the properties of these pins, and can be used as a reference.

Table-12: 4K@60 Encoder Module (based on SoM-I-SX660) Pin Assignment and Pin Voltages

| Description | Edge Connector Pin # | Direction | FPGA Pin # | Voltage | IO Standard |
|----------------------|----------------------|-----------|------------|---------|-------------|
| Reset In | 19 | Input | G18 | 3.3v | LVC MOS33 |
| Video Clock 0 | 105 | Input | AM15 | 3.3v | LVC MOS33 |
| Video Clock 1 | 107 | Input | AL15 | 3.3v | LVC MOS33 |
| Video Clock 2 | 113 | Input | E18 | 3.3v | LVC MOS33 |
| Video Clock 3 | 115 | Input | E17 | 3.3v | LVC MOS33 |
| Video Data 0 Luma[0] | 54 | Input | AF19 | 3.3v | LVC MOS33 |
| Video Data 0 Luma[1] | 56 | Input | AE19 | 3.3v | LVC MOS33 |
| Video Data 0 Luma[2] | 59 | Input | AD19 | 3.3v | LVC MOS33 |
| Video Data 0 Luma[3] | 61 | Input | AE18 | 3.3v | LVC MOS33 |
| Video Data 0 Luma[4] | 77 | Input | AF18 | 3.3v | LVC MOS33 |
| Video Data 0 Luma[5] | 79 | Input | AG18 | 3.3v | LVC MOS33 |
| Video Data 0 Luma[6] | 85 | Input | AC17 | 3.3v | LVC MOS33 |
| Video Data 0 Luma[7] | 87 | Input | AD17 | 3.3v | LVC MOS33 |
| Video Data 0 Luma[8] | 88 | Input | AE16 | 3.3v | LVC MOS33 |
| Video Data 0 Luma[9] | 90 | Input | AE17 | 3.3v | LVC MOS33 |
| Video Data 1 Luma[0] | 80 | Input | AP16 | 3.3v | LVC MOS33 |
| Video Data 1 Luma[1] | 82 | Input | AP17 | 3.3v | LVC MOS33 |
| Video Data 1 Luma[2] | 104 | Input | AL13 | 3.3v | LVC MOS33 |
| Video Data 1 Luma[3] | 106 | Input | AK13 | 3.3v | LVC MOS33 |
| Video Data 1 Luma[4] | 109 | Input | AN15 | 3.3v | LVC MOS33 |
| Video Data 1 Luma[5] | 111 | Input | AP15 | 3.3v | LVC MOS33 |
| Video Data 1 Luma[6] | 117 | Input | AN13 | 3.3v | LVC MOS33 |
| Video Data 1 Luma[7] | 119 | Input | AM13 | 3.3v | LVC MOS33 |
| Video Data 1 Luma[8] | 121 | Input | AN14 | 3.3v | LVC MOS33 |
| Video Data 1 Luma[9] | 123 | Input | AP14 | 3.3v | LVC MOS33 |
| Video Data 2 Luma[0] | 139 | Input | F19 | 3.3v | LVC MOS33 |
| Video Data 2 Luma[1] | 140 | Input | G20 | 3.3v | LVC MOS33 |
| Video Data 2 Luma[2] | 141 | Input | E19 | 3.3v | LVC MOS33 |
| Video Data 2 Luma[3] | 142 | Input | F20 | 3.3v | LVC MOS33 |

| | | | | | |
|------------------------|-----|-------|------|------|-----------|
| Video Data 2 Luma[4] | 144 | Input | K21 | 3.3v | LVC MOS33 |
| Video Data 2 Luma[5] | 146 | Input | J21 | 3.3v | LVC MOS33 |
| Video Data 2 Luma[6] | 148 | Input | K19 | 3.3v | LVC MOS33 |
| Video Data 2 Luma[7] | 150 | Input | L19 | 3.3v | LVC MOS33 |
| Video Data 2 Luma[8] | 169 | Input | F18 | 3.3v | LVC MOS33 |
| Video Data 2 Luma[9] | 170 | Input | G21 | 3.3v | LVC MOS33 |
| Video Data 3 Luma[0] | 69 | Input | N3 | 1.5v | LVC MOS15 |
| Video Data 3 Luma[1] | 131 | Input | M6 | 1.5v | LVC MOS15 |
| Video Data 3 Luma[2] | 133 | Input | M7 | 1.5v | LVC MOS15 |
| Video Data 3 Luma[3] | 143 | Input | J4 | 1.5v | LVC MOS15 |
| Video Data 3 Luma[4] | 145 | Input | J5 | 1.5v | LVC MOS15 |
| Video Data 3 Luma[5] | 147 | Input | N4 | 1.5v | LVC MOS15 |
| Video Data 3 Luma[6] | 149 | Input | N5 | 1.5v | LVC MOS15 |
| Video Data 3 Luma[7] | 153 | Input | L5 | 1.5v | LVC MOS15 |
| Video Data 3 Luma[8] | 155 | Input | L4 | 1.5v | LVC MOS15 |
| Video Data 3 Luma[9] | 157 | Input | K4 | 1.5v | LVC MOS15 |
| Video Data 0 Chroma[0] | 50 | Input | AM18 | 3.3v | LVC MOS33 |
| Video Data 0 Chroma[1] | 52 | Input | AN18 | 3.3v | LVC MOS33 |
| Video Data 0 Chroma[2] | 58 | Input | AK18 | 3.3v | LVC MOS33 |
| Video Data 0 Chroma[3] | 60 | Input | AL18 | 3.3v | LVC MOS33 |
| Video Data 0 Chroma[4] | 76 | Input | AM17 | 3.3v | LVC MOS33 |
| Video Data 0 Chroma[5] | 78 | Input | AN17 | 3.3v | LVC MOS33 |
| Video Data 0 Chroma[6] | 96 | Input | AL16 | 3.3v | LVC MOS33 |
| Video Data 0 Chroma[7] | 98 | Input | AM16 | 3.3v | LVC MOS33 |
| Video Data 0 Chroma[8] | 101 | Input | AL14 | 3.3v | LVC MOS33 |
| Video Data 0 Chroma[9] | 103 | Input | AK14 | 3.3v | LVC MOS33 |
| Video Data 1 Chroma[0] | 86 | Input | AH17 | 3.3v | LVC MOS33 |
| Video Data 1 Chroma[1] | 92 | Input | AG16 | 3.3v | LVC MOS33 |
| Video Data 1 Chroma[2] | 81 | Input | AJ17 | 3.3v | LVC MOS33 |
| Video Data 1 Chroma[3] | 83 | Input | AK17 | 3.3v | LVC MOS33 |
| Video Data 1 Chroma[4] | 84 | Input | AG17 | 3.3v | LVC MOS33 |
| Video Data 1 Chroma[5] | 89 | Input | AJ16 | 3.3v | LVC MOS33 |
| Video Data 1 Chroma[6] | 91 | Input | AK16 | 3.3v | LVC MOS33 |
| Video Data 1 Chroma[7] | 97 | Input | AJ15 | 3.3v | LVC MOS33 |
| Video Data 1 Chroma[8] | 99 | Input | AH15 | 3.3v | LVC MOS33 |
| Video Data 1 Chroma[9] | 100 | Input | AJ14 | 3.3v | LVC MOS33 |
| Video Data 2 Chroma[0] | 93 | Input | B22 | 3.3v | LVC MOS33 |
| Video Data 2 Chroma[1] | 95 | Input | A21 | 3.3v | LVC MOS33 |
| Video Data 2 Chroma[2] | 108 | Input | B21 | 3.3v | LVC MOS33 |
| Video Data 2 Chroma[3] | 110 | Input | B20 | 3.3v | LVC MOS33 |
| Video Data 2 Chroma[4] | 112 | Input | C20 | 3.3v | LVC MOS33 |
| Video Data 2 Chroma[5] | 114 | Input | D20 | 3.3v | LVC MOS33 |
| Video Data 2 Chroma[6] | 120 | Input | E21 | 3.3v | LVC MOS33 |
| Video Data 2 Chroma[7] | 122 | Input | D21 | 3.3v | LVC MOS33 |
| Video Data 2 Chroma[8] | 136 | Input | D22 | 3.3v | LVC MOS33 |
| Video Data 2 Chroma[9] | 138 | Input | C22 | 3.3v | LVC MOS33 |
| Video Data 3 Chroma[0] | 116 | Input | N9 | 1.5v | LVC MOS15 |
| Video Data 3 Chroma[1] | 118 | Input | P9 | 1.5v | LVC MOS15 |

| | | | | | |
|---------------------------|-----|--------|-----|------|-----------|
| Video Data 3 Chroma[2] | 124 | Input | R8 | 1.5v | LVC MOS15 |
| Video Data 3 Chroma[3] | 126 | Input | R7 | 1.5v | LVC MOS15 |
| Video Data 3 Chroma[4] | 128 | Input | N8 | 1.5v | LVC MOS15 |
| Video Data 3 Chroma[5] | 130 | Input | M8 | 1.5v | LVC MOS15 |
| Video Data 3 Chroma[6] | 132 | Input | K7 | 1.5v | LVC MOS15 |
| Video Data 3 Chroma[7] | 134 | Input | L8 | 1.5v | LVC MOS15 |
| Video Data 3 Chroma[8] | 135 | Input | N7 | 1.5v | LVC MOS15 |
| Video Data 3 Chroma[9] | 137 | Input | P7 | 1.5v | LVC MOS15 |
| SPDIF Audio | 174 | Input | H20 | 3.3v | LVC MOS33 |
| Transport Stream Buffer | 29 | Input | L1 | 1.5v | LVC MOS15 |
| Transport Stream Clock | 31 | Output | K1 | 1.5v | LVC MOS15 |
| Transport Stream Data | 33 | Output | K2 | 1.5v | LVC MOS15 |
| Transport Stream Data [0] | 46 | Output | J1 | 1.5v | LVC MOS15 |
| Transport Stream Data [1] | 48 | Output | J2 | 1.5v | LVC MOS15 |
| Transport Stream Data [2] | 63 | Output | L3 | 1.5v | LVC MOS15 |
| Transport Stream Data [3] | 65 | Output | K3 | 1.5v | LVC MOS15 |
| Uart_tx | 163 | Output | H17 | 3.3v | LVC MOS33 |
| Uart_rx | 164 | Input | J17 | 3.3v | LVC MOS33 |

8.2 Signal Formats

8.2.1 Clock Signals (Input)

The 4k@60 encoder has 4 input clocks, **Video Clock 0** (pin # 105), **Video Clock 1** (pin # 107), **Video Clock 2** (pin # 113), and **Video Clock 3** (pin # 115). These clocks match the four of 3G SDI inputs for one 4k@60 video. The clock rate is 148.5MHz, and the video data are sampled at dual data rate, at both the rising and falling edges of the clock. However, if one 4k input is used on the carrier board, such as HDMI 2.0 or 12G SDI, only **Video Clock 0** is needed which takes the input video clock is 148.5 MHz for 4k@60.

8.2.2 Video Data Signals (Input)

The input to the encoder module is raw video data in YUV format (4:2:2 or 4:2:0), with 40 input lines: **Video Data 0 Luma[0]** to **Video Data 3 Luma[9]**, for Luma, and, 40 input lines: **Video Data 0 Chroma[0]** to **Video Data 3 Chroma[9]**, for the Chroma. The precision is either 8 bits or 10 bits. For 8-bit precision, the Most Significant Luma and Chroma pins (Luma[2] to Luma[9], Chroma[2] to Chroma[9]) are used.

The video data are sampled at both the rising and falling edges of the clock. The clock rates will correspond to the resolution and frame rate, as discussed in Section **8.2.1**.

8.2.3 Audio Data Signals (Input)

Input line **SPDIF Audio** is for PCM audio input, in **SPDIF** frames. An **SPDIF** transmitter is required to send the PCM data to the encoder module. Refer to the **SPDIF** protocol documents for details.

8.2.4 TS stream Signals (Output)

The output of the encoder module is MPEG Transport Stream (TS), which is sent out from the module by 4 Dual data rate parallel lines: **Transport Stream Data[0]** to **Transport Stream Data[4]**, along with the Transport Stream output data clock **Transport Stream Clock** (pin # 31). The frequency of the Transport Stream Data clock is 27MHz.

Transport Stream Buffer Ready (pin # 28) and **Transport Stream Data Valid** (pin # 33) are the signals to inform the user side to take over the signals.

8.2.5 Encoder Control Signals (Input and Output)

Uart_rx and **Uart_tx** are the API pins for controlling the operations of the encoder. **Uart_rx** receives the command from an external control device. **Uart_tx** sends the encoder information to the control device. Refer to the **Uart** standard for details of **Uart** operations. The SOC API User Manual provides the register map for the API control. Refer to the [Encoder API User Manual](#) for more details.

An external reset **PS Soft Reset_B** (pin # 156) is available. This pin allows the user to reset the encoder when necessary. A low signal will trigger a reset. The reset signal should be maintained at high or left unconnected when in normal operation mode.

8.3 Power Rails of SoM-I-SX660

Refer to Appendix-D for the pins of power and ground on the edge connector of the SoM-I-SX660 module. The power rails are: 1.0V, 1.2V, 1.3V, 1.5V, 2.5V, and 3.3V. However, only the 3.3V and 2.5V power supplies are required. The rest of the power rails are not used, which should be ignored.

8.4 Power Requirement and Supply Current

The SoM-I-SX660 requires only two power rails to be supplied to the module from the carrier board, which are 3.3V and 2.5V. All the rest of the voltages are created on the module. Table-13 provide the currents required for the two power rails, which can be used for all 4K@60 encoders and decoders.

Table-13: Power estimation for the H.264 4k@60 encoder module

| Power Rail | Current (A) | Power (W) |
|------------|-------------|-----------|
| 3.3V | 3.2 | 10.5 |
| 2.5V | 1.7 | 4.2 |

Since the encoder module normally shares the power supplies with the carrier board (user PCB). The power design should be considered for both the module and the carrier board. SOC licenses the schematics of carrier boards. The VTR-4000C discussed in Section 19 of this document is for 4k resolution. The reference design provides not

only the power system design, but also the I/O port designs, such as SDI, HDMI, Mini-USB, etc. Contact SOC sale at: sales@soctechnologies.com for design licensing information.

8.5 Booting Sequence and Booting Time

The module design has considered the booting sequence of the FPGA on the module. Therefore, there is no booting sequence requirement by the module for carrier board designs, i.e. the power rails can be supplied to the module at the same time or at any sequence. Once all of the power rails are supplied, the module will start to boot. The booting time is less than 2 seconds.

(Left Empty here intentionally)

9. The H.264 4K@60 Decoder Modules

9.1 Pin Assignments and Pin Voltages

The modules for H.264 4K@60 resolution decoder use the SoM-I-SX660 as well. This section details the pin assignment and pin voltages for H.264 4K@60 decoder modules based on the SoM-I-SX660 hardware.

Table-14 shows the pin assignments and the pin voltages for H.264 4k@60 decoder modules based on the SoM-I-SX660.

The schematics of SoM-I-SX660 edge connector are attached in Appendix-D of this document. Appendix-D shows the pin numbers for data, clock, control, and power, which are connected to the FPGA.

It should be noted that the 4K@60 encoder and decoder pin assignments are symmetrical, i.e. the video input pins on the encoder module become the video output pins on the decoder module.

Table-14: H.264 4K@60 Decoder Module (based on SoM-I-SX660) Pin Assignment

| Description | Edge Connector Pin # | Direction | FPGA Pin # | Voltage | IO Standard |
|----------------------|----------------------|-----------|------------|---------|-------------|
| Reset In | 19 | Input | G18 | 3.3v | LVC MOS33 |
| Video Clock 0 | 100 | Output | AJ14 | 3.3v | LVC MOS33 |
| Video Clock 1 | 89 | Output | AJ16 | 3.3v | LVC MOS33 |
| Video Clock 2 | 93 | Output | B22 | 3.3v | LVC MOS33 |
| Video Clock 3 | 135 | Output | N7 | 1.5v | LVC MOS15 |
| Video Data 0 Luma[0] | 54 | Output | AF19 | 3.3v | LVC MOS33 |
| Video Data 0 Luma[1] | 56 | Output | AE19 | 3.3v | LVC MOS33 |
| Video Data 0 Luma[2] | 59 | Output | AD19 | 3.3v | LVC MOS33 |
| Video Data 0 Luma[3] | 61 | Output | AE18 | 3.3v | LVC MOS33 |
| Video Data 0 Luma[4] | 77 | Output | AF18 | 3.3v | LVC MOS33 |
| Video Data 0 Luma[5] | 79 | Output | AG18 | 3.3v | LVC MOS33 |
| Video Data 0 Luma[6] | 85 | Output | AC17 | 3.3v | LVC MOS33 |
| Video Data 0 Luma[7] | 87 | Output | AD17 | 3.3v | LVC MOS33 |
| Video Data 0 Luma[8] | 88 | Output | AE16 | 3.3v | LVC MOS33 |
| Video Data 0 Luma[9] | 90 | Output | AE17 | 3.3v | LVC MOS33 |
| Video Data 1 Luma[0] | 56 | Output | AP16 | 3.3v | LVC MOS33 |
| Video Data 1 Luma[1] | 80 | Output | AP17 | 3.3v | LVC MOS33 |
| Video Data 1 Luma[2] | 82 | Output | AL13 | 3.3v | LVC MOS33 |
| Video Data 1 Luma[3] | 104 | Output | AK13 | 3.3v | LVC MOS33 |
| Video Data 1 Luma[4] | 106 | Output | AN15 | 3.3v | LVC MOS33 |
| Video Data 1 Luma[5] | 109 | Output | AP15 | 3.3v | LVC MOS33 |
| Video Data 1 Luma[6] | 111 | Output | AN13 | 3.3v | LVC MOS33 |
| Video Data 1 Luma[7] | 117 | Output | AM13 | 3.3v | LVC MOS33 |
| Video Data 1 Luma[8] | 119 | Output | AN14 | 3.3v | LVC MOS33 |
| Video Data 1 Luma[9] | 121 | Output | AP14 | 3.3v | LVC MOS33 |

| | | | | | |
|------------------------|-----|--------|------|------|-----------|
| Video Data 2 Luma[0] | 139 | Output | F19 | 3.3v | LVC MOS33 |
| Video Data 2 Luma[1] | 140 | Output | G20 | 3.3v | LVC MOS33 |
| Video Data 2 Luma[2] | 141 | Output | E19 | 3.3v | LVC MOS33 |
| Video Data 2 Luma[3] | 142 | Output | F20 | 3.3v | LVC MOS33 |
| Video Data 2 Luma[4] | 144 | Output | K21 | 3.3v | LVC MOS33 |
| Video Data 2 Luma[5] | 146 | Output | J21 | 3.3v | LVC MOS33 |
| Video Data 2 Luma[6] | 148 | Output | K19 | 3.3v | LVC MOS33 |
| Video Data 2 Luma[7] | 150 | Output | L19 | 3.3v | LVC MOS33 |
| Video Data 2 Luma[8] | 115 | Output | E17 | 3.3v | LVC MOS33 |
| Video Data 2 Luma[9] | 167 | Output | G21 | 3.3v | LVC MOS33 |
| Video Data 3 Luma[0] | 69 | Output | N3 | 1.5v | LVC MOS15 |
| Video Data 3 Luma[1] | 153 | Output | L5 | 1.5v | LVC MOS15 |
| Video Data 3 Luma[2] | 133 | Output | L6 | 1.5v | LVC MOS15 |
| Video Data 3 Luma[3] | 143 | Output | J4 | 1.5v | LVC MOS15 |
| Video Data 3 Luma[4] | 145 | Output | J5 | 1.5v | LVC MOS15 |
| Video Data 3 Luma[5] | 147 | Output | N4 | 1.5v | LVC MOS15 |
| Video Data 3 Luma[6] | 149 | Output | N5 | 1.5v | LVC MOS15 |
| Video Data 3 Luma[7] | 159 | Output | M2 | 1.5v | LVC MOS15 |
| Video Data 3 Luma[8] | 155 | Output | L4 | 1.5v | LVC MOS15 |
| Video Data 3 Luma[9] | 157 | Output | K4 | 1.5v | LVC MOS15 |
| Video Data 0 Chroma[0] | 50 | Output | AM18 | 3.3v | LVC MOS33 |
| Video Data 0 Chroma[1] | 52 | Output | AN18 | 3.3v | LVC MOS33 |
| Video Data 0 Chroma[2] | 58 | Output | AK18 | 3.3v | LVC MOS33 |
| Video Data 0 Chroma[3] | 60 | Output | AL18 | 3.3v | LVC MOS33 |
| Video Data 0 Chroma[4] | 76 | Output | AM17 | 3.3v | LVC MOS33 |
| Video Data 0 Chroma[5] | 78 | Output | AN17 | 3.3v | LVC MOS33 |
| Video Data 0 Chroma[6] | 96 | Output | AL16 | 3.3v | LVC MOS33 |
| Video Data 0 Chroma[7] | 98 | Output | AM16 | 3.3v | LVC MOS33 |
| Video Data 0 Chroma[8] | 101 | Output | AL14 | 3.3v | LVC MOS33 |
| Video Data 0 Chroma[9] | 103 | Output | AK14 | 3.3v | LVC MOS33 |
| Video Data 1 Chroma[0] | 38 | Output | AH18 | 3.3v | LVC MOS33 |
| Video Data 1 Chroma[1] | 40 | Output | AH19 | 3.3v | LVC MOS33 |
| Video Data 1 Chroma[2] | 81 | Output | AJ17 | 3.3v | LVC MOS33 |
| Video Data 1 Chroma[3] | 83 | Output | AK17 | 3.3v | LVC MOS33 |
| Video Data 1 Chroma[4] | 84 | Output | AG17 | 3.3v | LVC MOS33 |
| Video Data 1 Chroma[5] | 86 | Output | AH17 | 3.3v | LVC MOS33 |
| Video Data 1 Chroma[6] | 91 | Output | AK16 | 3.3v | LVC MOS33 |
| Video Data 1 Chroma[7] | 97 | Output | AJ15 | 3.3v | LVC MOS33 |
| Video Data 1 Chroma[8] | 99 | Output | AH15 | 3.3v | LVC MOS33 |
| Video Data 1 Chroma[9] | 105 | Output | AM15 | 3.3v | LVC MOS33 |
| Video Data 2 Chroma[0] | 113 | Output | E18 | 3.3v | LVC MOS33 |
| Video Data 2 Chroma[1] | 95 | Output | A21 | 3.3v | LVC MOS33 |
| Video Data 2 Chroma[2] | 108 | Output | B21 | 3.3v | LVC MOS33 |
| Video Data 2 Chroma[3] | 110 | Output | B20 | 3.3v | LVC MOS33 |
| Video Data 2 Chroma[4] | 112 | Output | C20 | 3.3v | LVC MOS33 |
| Video Data 2 Chroma[5] | 114 | Output | D20 | 3.3v | LVC MOS33 |
| Video Data 2 Chroma[6] | 120 | Output | E21 | 3.3v | LVC MOS33 |
| Video Data 2 Chroma[7] | 122 | Output | D21 | 3.3v | LVC MOS33 |

| | | | | | |
|---------------------------|-----|--------|------|------|-----------|
| Video Data 2 Chroma[8] | 136 | Output | D22 | 3.3v | LVC MOS33 |
| Video Data 2 Chroma[9] | 138 | Output | C22 | 3.3v | LVC MOS33 |
| Video Data 3 Chroma[0] | 116 | Output | N9 | 1.5v | LVC MOS15 |
| Video Data 3 Chroma[1] | 118 | Output | P9 | 1.5v | LVC MOS15 |
| Video Data 3 Chroma[2] | 124 | Output | R8 | 1.5v | LVC MOS15 |
| Video Data 3 Chroma[3] | 126 | Output | R7 | 1.5v | LVC MOS15 |
| Video Data 3 Chroma[4] | 67 | Output | N2 | 1.5v | LVC MOS15 |
| Video Data 3 Chroma[5] | 130 | Output | M8 | 1.5v | LVC MOS15 |
| Video Data 3 Chroma[6] | 132 | Output | K7 | 1.5v | LVC MOS15 |
| Video Data 3 Chroma[7] | 134 | Output | L8 | 1.5v | LVC MOS15 |
| Video Data 3 Chroma[8] | 128 | Output | N8 | 1.5v | LVC MOS15 |
| Video Data 3 Chroma[9] | 137 | Output | P7 | 1.5v | LVC MOS15 |
| Video Out Mode | 161 | Output | M3 | 1.5v | LVC MOS15 |
| Video Clock in | 107 | Input | AL15 | 1.5v | LVC MOS15 |
| SPDIF Audio | 174 | Output | H20 | 3.3v | LVC MOS33 |
| Transport Stream Ready | 29 | Output | L1 | 1.5v | LVC MOS15 |
| Transport Stream Data | 33 | Input | K2 | 1.5v | LVC MOS15 |
| Transport Stream Clock in | 131 | Input | K6 | 1.5v | LVC MOS15 |
| Transport Stream Data [0] | 46 | Input | J1 | 1.5v | LVC MOS15 |
| Transport Stream Data [1] | 48 | Input | J2 | 1.5v | LVC MOS15 |
| Transport Stream Data [2] | 63 | Input | L3 | 1.5v | LVC MOS15 |
| Transport Stream Data [3] | 65 | Input | K3 | 1.5v | LVC MOS15 |
| Uart_tx | 163 | Output | H17 | 3.3v | LVC MOS33 |
| Uart_rx | 164 | Input | J17 | 3.3v | LVC MOS33 |

9.2 Signal Formats

9.2.1 Video Clock Signal (Output)

The **Video Clock** signal (pin # 105) is the clock signal that provides the timing for the parallel luma, chroma, as well as the **Video Horizontal Sync** and **Video Vertical Sync** signals. The default is 148.5MHz for 4K@60.

9.2.2 Video Data Signals (Output)

The output of the H.264 4k@30 decoder module is the decoded video data in YUV format (4:2:2 or 4:2:0), with 40 output lines: **Video Data 0 Luma[0]** to **Video Data 3 Luma[9]**, for Luma, and, 40 lines: **Video Data 0 Chroma[0]** to **Video Data 3 Chroma[9]**, for the Chroma. The precision can be either 8-bit precision or 10-bit precision. For 8-bit precision, the Most Significant Bits of luma and chroma output lines (Luma[2] to Luma[9], Chroma[2] to Chroma[9]) are used.

In addition to the video Luma and Chroma data signals, the **Video Horizontal Sync** and **Video Vertical Sync** signals are provided for frame synchronization. The **Video Display Enable** signal is a part of the **Video Horizontal Sync** and **Video Vertical Sync** system, where high signal indicates active video pixels.

9.2.3 Audio Data Signals (Output)

Line **SPDIF Audio** is for PCM audio output, in **SPDIF** frames. An **SPDIF** transmitter is included in the module to send the PCM data out via the decoder edge pins. Refer to the **SPDIF** protocol documents for details.

9.2.4 Decoder Control Signals (Input and output)

Uart_rx and **Uart_tx** are the API pins for controlling the operations of the decoder. **Uart_rx** receives the command from an external control device. **Uart_tx** send the decoder information to the control device. Refer to the **Uart** standard for details of **Uart** operations. The SOC API User Manual provides the register map for the API control. Refer to the [Decoder API User Manual](#) for details.

9.3 Power Rails of SoM-I-SX660

The power rails for H.264 4k@60 decoder module are the same as the H.264 4k@60 encoder. Refer to Appendix-C for the pins of power and ground on the edge connector of the SoM-I-SX660 module.

9.4 Power Requirement and Supply Current

The SoM-I-SX660 requires only two power rails to be supplied to the module from the carrier board, which are 3.3V and 2.5V. All the rest of the voltages are created on the module. Table-15 provides the currents required for the two power rails, which can be used for all 4K@60 encoders and decoders. Please note that Table-13 and Table-15 are identical, since the power supplies for the encoder and decoder models are the same.

Table-15: Power estimation for the H.264 4k@60 decoder module

| Power Rail | Current (A) | Power (W) |
|------------|-------------|-----------|
| 3.3V | 3.2 | 10.5 |
| 2.5V | 1.7 | 4.2 |

Since the decoder module normally shares the power supplies with the carrier board (user PCB). The power design should be considered for both the module and the carrier board. SOC licenses the schematics of carrier boards. The VTR-4000C discussed in Section 19 of this document is for 4k resolution. The reference design provides not only the power system design, but also the I/O port designs, such as SDI, HDMI, Mini-USB, etc. Contact SOC sale at: sales@soctechnologies.com for design licensing information.

9.5 Booting Sequence and Booting Time

The module design has considered the booting sequence of the FPGA on the module. Therefore, there is no booting sequence requirement by the module for carrier board designs, i.e. the power rails can be supplied to the module at the same time or at any sequence. Once the all of the power rails are supplied, the module will start to boot. The booting time is less than 2 seconds.

(Left Empty here intentionally)

10. The H.265 HD Encoder Modules

10.1 Pin Assignments and Pin Voltages

The SoM-X-Z7045 is used for H.265 HD (1080@30 or 1080@60) resolution encoder modules. It is noted that the H.265 HD encoder can use either the SoM-X-Z7045 or SoM-I-SX660. This Section provides the pin assignments and electrical properties for H.265 HD encoder module based on the SoM-X-Z7045. Table-16 lists the pin assignments and the pin voltages. Pin assignments for the H.265 HD encoder based on the SoM-I-SX660 are provided separately when needed.

The schematics of SoM-X-Z7045 edge connector are attached in Appendix-C of this document, which shows the pin numbers for data, clock, control, and power. It should be noted that the encoder module uses only some of the edge pins, and not all of the edge pins are used.

Table-16 also lists the FPGA pin numbers that are connected to the edge pins assigned to the encoder. The Zynq-7000 datasheet provides further information regarding the properties of these pins, and can be used as a reference for user PCB designs that uses the SoM-X-Z7045.

Table 16: HD Encoder Module (based on SoM-X-Z7045) Pin Assignment and Pin Voltages

| Description | SoM-X-Z7045 Edge Connector Pin # | Direction | FPGA Pin # | Voltage | IO Standard |
|-------------------------------|----------------------------------|-----------|------------|---------|-------------|
| PS Soft Reset_B | 156 | Input | B19 | 3.3V | LVC MOS33 |
| Video Clock | 105 | Input | AG21 | 3.3V | LVC MOS33 |
| Video Horizontal Sync | 133 | Input | W24 | 1.5V | LVC MOS15 |
| Video Vertical Sync | 113 | Input | AF22 | 3.3V | LVC MOS33 |
| Video Display Enable | 67 | Input | AD18 | 1.5V | LVC MOS15 |
| Video Data Luma[0] | 107 | Input | AH21 | 3.3V | LVC MOS33 |
| Video Data Luma[1] | 122 | Input | AH29 | 3.3V | LVC MOS33 |
| Video Data Luma[2] | 115 | Input | AE22 | 3.3V | LVC MOS33 |
| Video Data Luma[3] | 146 | Input | AF28 | 3.3V | LVC MOS33 |
| Video Data Luma[4] | 148 | Input | AF29 | 3.3V | LVC MOS33 |
| Video Data Luma[5] | 150 | Input | AG29 | 3.3V | LVC MOS33 |
| Video Data Luma[6] | 100 | Input | AH23 | 3.3V | LVC MOS33 |
| Video Data Luma[7] | 102 | Input | AH24 | 3.3V | LVC MOS33 |
| Video Data Luma[8] | 104 | Input | AJ25 | 3.3V | LVC MOS33 |
| Video Data Luma[9] | 106 | Input | AK25 | 3.3V | LVC MOS33 |
| Video Data Chroma[0] | 108 | Input | AJ26 | 3.3V | LVC MOS33 |
| Video Data Chroma[1] | 110 | Input | AK26 | 3.3V | LVC MOS33 |
| Video Data Chroma[2] | 112 | Input | AH26 | 3.3V | LVC MOS33 |
| Video Data Chroma[3] | 114 | Input | AH27 | 3.3V | LVC MOS33 |
| Video Data Chroma[4] | 136 | Input | AK27 | 3.3V | LVC MOS33 |
| Video Data Chroma[5] | 138 | Input | AK28 | 3.3V | LVC MOS33 |
| Video Data Chroma[6] | 139 | Input | AJ28 | 3.3V | LVC MOS33 |
| Video Data Chroma[7] | 141 | Input | AJ29 | 3.3V | LVC MOS33 |
| Video Data Chroma[8] | 140 | Input | AJ30 | 3.3V | LVC MOS33 |
| Video Data Chroma[9] | 142 | Input | AK30 | 3.3V | LVC MOS33 |
| SPDIF Audio | 27 | Input | Y20 | 1.5V | LVC MOS15 |
| Transport Stream Buffer Ready | 29 | Input | AA20 | 1.5V | LVC MOS15 |

| | | | | | |
|-----------------------------|-----|--------|------|------|-----------|
| Transport Stream Clock | 31 | Output | AA18 | 1.5V | LVC MOS15 |
| Transport Stream Data Valid | 33 | Output | AA19 | 1.5V | LVC MOS15 |
| Transport Stream Data[0] | 152 | Output | AF30 | 3.3V | LVC MOS33 |
| Transport Stream Data[1] | 154 | Output | AG30 | 3.3V | LVC MOS33 |
| Transport Stream Data[2] | 158 | Output | AE30 | 3.3V | LVC MOS33 |
| Transport Stream Data[3] | 160 | Output | AB29 | 3.3V | LVC MOS33 |
| Transport Stream Data[4] | 162 | Output | AB30 | 3.3V | LVC MOS33 |
| Transport Stream Data[5] | 164 | Output | AA27 | 3.3V | LVC MOS33 |
| Transport Stream Data[6] | 166 | Output | AA28 | 3.3V | LVC MOS33 |
| Transport Stream Data[7] | 120 | Output | AH28 | 3.3V | LVC MOS33 |
| Uart_tx | 90 | Output | AK15 | 3.3V | LVC MOS33 |
| Uart_rx | 88 | Input | AJ15 | 3.3V | LVC MOS33 |

10.2 Signal Formats

10.2.1 Video Clock Signal (Input)

The **Video Clock** signal (pin # 105) has two functions: (1) It is the clock for the input video data, and (2) it is the clock that drives the encoder engine.

The **Video Clock** signal usually comes from the video input interface chip, such as HDMI or SDI. It is the clock for the input video data. It is also used for driving the encoder engine. The frequency varies according to the resolution of the video input. The following are the clock frequencies for standard video resolutions.

4. 27MHz, for SD resolution
5. 74.25MHz, for 720@60 and 1080@30
6. 148.5MHz, for 1080@60

10.2.2 Video Data Signals (Input)

The input to the encoder module (H.264 or MPEG-2) is raw video data in YUV format (4:2:2 or 4:2:0), with 10 input lines: **Video Data Luma[0]** to **Video Data Luma[9]**, for Luma; and, 10 input lines: **Video Data Chroma[0]** to **Video Data Chroma[9]**, for the Chroma. The precision can be either 8-bit or 10-bit. When 8-bit precision is used, **Video Data Luma[0]**, **Video Data Luma[1]**, **Video Data Chroma[0]**, and **Video Data Chroma[1]** are zeros.

In addition to the video Luma and Chroma data signals, the **Video Horizontal Sync** and **Video Vertical Sync** signals are required for frame synchronization. A **Video Clock** (refer to Section 10.2.1 for the clock frequencies) is required, which provides the timing for the parallel input of luma, chroma, as well as for the **Video Horizontal Sync** and **Video Vertical Sync** signals. The **Video Display Enable** signal is a part of the **Video Horizontal Sync** and **Video Vertical Sync** system, where high signal indicates active video pixels. For example, an HDMI input interface chip will output the **Display Enable signal** at high, when active pixels are being sent out. The video data are sampled at the rising edge of the clock. The clock rates will correspond to the resolution and frame rate, as discussed in Section 10.2.1.

10.2.3 Audio Data Signals (Input)

Input line **SPDIF Audio** is for PCM audio input, in **SPDIF** frames. An **SPDIF** transmitter is required to send the PCM data to the encoder module. Refer to the **SPDIF** protocol documents for details.

10.2.4 TS stream Signals (Output)

The output of the encoder module is MPEG Transport Stream (TS), which is sent out from the module by 8 parallel lines: **Transport Stream Data[0]** to **Transport Stream Data[7]**; along with the Transport Stream output data clock **Transport Stream Clock**. The frequency of the Transport Stream Data clock is 27MHz.

Transport Stream Buffer Ready and **Transport Stream Data Valid** are the signals to inform the user side to take over the signals.

10.2.5 Encoder Control Signals (Input and Output)

Uart_rx and **Uart_tx** are the API pins for controlling the operations of the encoder. **Uart_rx** receives the command from external control device. **Uart_tx** sends the encoder information to the control device. Refer to the **Uart** standard for details of **Uart** operations. The SOC API User Manual provides the register map for the API control. Refer to the [Encoder API User Manual](#) for more details.

An external reset PS Soft Reset_B (pin # 156) is available. This pin allows the user to reset the encoder when necessary. A low signal will trigger a reset. The reset signal should be maintained at high or left unconnected when in normal operation mode.

10.3 Power Rails of SoM-X-Z45

Refer to Appendix-C for the pins of power and ground on the edge connector of the SoM-X-Z7045 module.

10.4 Power Requirement and Supply Current

The total power, at operation, required by a given encoder module ranges from 2 to 10 watts, depending on the resolution and frame rate. Since the total power is delivered over 6 power rails, each individual power rail deliveries only a portion of the total power. However, the power is not evenly distributed among the rails. Table-17 lists the power estimation, at 1080p@60 resolution, for PCB design purpose. It should be noted that the measured real power consumption is lower than the estimated power consumption, as the power estimation is for PCB design uses.

It should be noted that the power rails of 1.8v is generated on the module, using the 2.5v power input from the edge pin. PCB designers need only to design the 6 power rails listed in Table-17, as the 1.8v is generated on the module.

Table-17: Power estimation for the encoder module (1080p@60 resolution)

| Power Rail | Current (A) | Power (W) |
|------------|-------------|-----------|
| 3.3V | 0.37 | 1.22 |
| 2.5V | 0.99 | 2.48 |
| 1.5V | 1.25 | 1.87 |
| 1.3V | 0.37 | 0.58 |
| 1.2V | 0.75 | 0.90 |
| 1.0V | 3.39 | 3.39 |

Since the encoder module normally shares the power supplies with the carrier board (user PCB). The power design should be considered for both. SOC licenses the schematics of carrier boards, such as the VTR-S1000 and VTR-4000C discussed in Section 19 of this document. The reference designs provide not only the power system design, but also the I/O port designs, such as SDI, HDMI, Mini-USB, etc. Please contact SOC sale at: sales@soctechnologies.com for design licensing details.

10.5 Booting Sequence and Booting Time

The module design has considered the booting sequence of the FPGA on the module. Therefore, there is no booting sequence requirement by the module for carrier board designs, i.e. the power rails can be supplied to the module at the same time or at any sequence. Once all of the power rails are supplied, the module will start to boot. The booting time is less than 2 seconds.

(Left Empty here intentionally)

11. The H.265 HD Decoder Modules

11.1 Pin Assignments and Pin Voltages

The H.265 HD 1080@30 and 1080@60 decoders have the same pin assignment. The module for HD resolution decoding uses the SoM-X-Z7045. Also, pin assignments for the H.265 HD decoder based on the SoM-I-SX660 are provided separately when needed.

This section details the pin assignments and pin voltages for the H.265 HD decoder modules. Table-18 shows the pin assignments and the pin voltages.

The schematics of SoM-X-Z7045 edge connector are attached in Appendix-C of this document. Appendix-C shows the pin numbers for data, clock, control, and power, which are connected to the FPGA. It should be noted that the decoder module uses only some of the available edge pins that are connected to the FPGA (some of the pins are not used).

It should also be noted that the HD encoder and decoder pin assignments are symmetrical, i.e. the video input pins on the encoder module become the video output pins on the decoder module.

Table-18: HD Decoder Module (based on SoM-X-Z7045) Pin Assignment

| Description | SoM-X-Z7045 Edge Connector Pin # | Direction | FPGA Pin # | Voltage | IO Standard |
|-----------------------|----------------------------------|-----------|------------|---------|-------------|
| PS Soft Reset_B | 156 | Input | B19 | 3.3V | LVC MOS33 |
| Decoder Clock | 80 | Input | AB13 | 3.3V | LVC MOS33 |
| Video Clock | 105 | Output | AG21 | 3.3V | LVC MOS33 |
| Video Horizontal Sync | 133 | Output | W24 | 1.5V | LVC MOS15 |
| Video Vertical Sync | 113 | Output | AF22 | 3.3V | LVC MOS33 |
| Video Display Enable | 67 | Output | AD18 | 1.5V | LVC MOS15 |
| Video Data Luma[0] | 107 | Output | AH21 | 3.3V | LVC MOS33 |
| Video Data Luma[1] | 122 | Output | AH29 | 3.3V | LVC MOS33 |
| Video Data Luma[2] | 115 | Output | AE22 | 3.3V | LVC MOS33 |
| Video Data Luma[3] | 146 | Output | AF28 | 3.3V | LVC MOS33 |
| Video Data Luma[4] | 148 | Output | AF29 | 3.3V | LVC MOS33 |
| Video Data Luma[5] | 150 | Output | AG29 | 3.3V | LVC MOS33 |
| Video Data Luma[6] | 100 | Output | AH23 | 3.3V | LVC MOS33 |
| Video Data Luma[7] | 102 | Output | AH24 | 3.3V | LVC MOS33 |
| Video Data Luma[8] | 104 | Output | AJ25 | 3.3V | LVC MOS33 |
| Video Data Luma[9] | 106 | Output | AK25 | 3.3V | LVC MOS33 |
| Video Data Chroma[0] | 108 | Output | AJ26 | 3.3V | LVC MOS33 |
| Video Data Chroma[1] | 110 | Output | AK26 | 3.3V | LVC MOS33 |
| Video Data Chroma[2] | 112 | Output | AH26 | 3.3V | LVC MOS33 |
| Video Data Chroma[3] | 114 | Output | AH27 | 3.3V | LVC MOS33 |
| Video Data Chroma[4] | 136 | Output | AK27 | 3.3V | LVC MOS33 |
| Video Data Chroma[5] | 138 | Output | AK28 | 3.3V | LVC MOS33 |
| Video Data Chroma[6] | 139 | Output | AJ28 | 3.3V | LVC MOS33 |
| Video Data Chroma[7] | 141 | Output | AJ29 | 3.3V | LVC MOS33 |
| Video Data Chroma[8] | 140 | Output | AJ30 | 3.3V | LVC MOS33 |
| Video Data Chroma[9] | 142 | Output | AK30 | 3.3V | LVC MOS33 |

| | | | | | |
|---|-----|--------|------|------|-----------|
| SPDIF Audio | 27 | Output | Y20 | 1.5V | LVC MOS15 |
| Transport Stream Clock (27MHz) | 93 | Input | AA18 | 1.5V | LVC MOS15 |
| Transport Stream Data Valid | 106 | Input | AA19 | 1.5V | LVC MOS15 |
| Transport Stream Data[0] | 77 | Input | AF30 | 3.3V | LVC MOS33 |
| Transport Stream Data[1] | 79 | Input | AG30 | 3.3V | LVC MOS33 |
| Transport Stream Data[2] | 81 | Input | AE30 | 3.3V | LVC MOS33 |
| Transport Stream Data[3] | 83 | Input | AB29 | 3.3V | LVC MOS33 |
| Transport Stream Data[4] | 85 | Input | AB30 | 3.3V | LVC MOS33 |
| Transport Stream Data[5] | 87 | Input | AA27 | 3.3V | LVC MOS33 |
| Transport Stream Data[6] | 89 | Input | AA28 | 3.3V | LVC MOS33 |
| Transport Stream Data[7] | 91 | Input | AH28 | 3.3V | LVC MOS33 |
| Uart_tx | 90 | Output | AK15 | 3.3V | LVC MOS33 |
| Uart_rx | 88 | Input | AJ15 | 3.3V | LVC MOS33 |

11.2 Signal Formats

11.2.1 Clock Signals

When an SDI port on the carrier board is used to send out the decoded video data, the SDI clock should be connected to the Decoder Clock and Use Decoder Clock should be tied high. This will automatically synchronize the decoder outputs with the SDI interface. Internally generated clock is used if Use Decoder Clock is tied low.

The SDI clock frequencies are:

8. 27MHz, for SD resolution
9. 74.25MHz, for 720@60 and 1080@30
10. 148.5MHz, for 1080@60

The **Video Clock** signal (pin # 105) is the clock for the video data output by the decoder. The frequency of the **Video clock** is determined by the video resolution, which are:

11. 27MHz, for SD resolution
12. 74.25MHz, for 720@60 and 1080@30
13. 148.5MHz, for 1080@60.

11.2.2 Video Data Signals (Output)

The output of the HD decoder module (H.264 or MPEG-2) is the decoded video data in YUV format (4:2:2 or 4:2:0), with 10 input lines: **Video Data Luma[0]** to **Video Data Luma[9]**, for Luma; and 10 lines, **Video Data Chroma[0]** to **Video Data Chroma[9]**, for the Chroma. The precision can be either 8-bit or 10-bit. When 8-bit precision is used, **Video Data Luma[0]**, **Video Data Luma[1]**, **Video Data Chroma[0]**, and **Video Data Chroma[1]** are zeros.

In addition to the video Luma and Chroma data signals, the **Video Horizontal Sync** and **Video Vertical Sync** signals are provided for frame synchronization. A **Video Clock** (refer to Section 11.2.1 for the clock frequencies) is sent out, which provides the timing for the parallel inputs of luma, chroma, as well as the **Video Horizontal Sync** and **Video Vertical Sync** signals. The **Video Display Enable** signal (pin #150) is a part of the **Video Horizontal Sync** and **Video Vertical Sync** system, where high signal indicates active video pixels.

Output data are sampled at the rising edge of the clock. (The clock rates will correspond to the resolution and frame rate, as discussed in Section 11.2.1.)

11.2.3 Audio Data Signals (Output)

Line **SPDIF Audio** is for PCM audio output, in **SPDIF** frames. An **SPDIF** transmitter is included in the module to send the PCM data out via the decoder edge pins. Refer to the **SPDIF** protocol documents for details.

11.2.4 TS Stream Signals (Input)

The input of the decoder module is an MPEG transport stream, which is sent into the module by 8 parallel lines: **Transport Stream Data[0]** to **Transport Stream Data[7]**. **Transport Stream Clock** (27MHz) is the clock for the **Transport Stream Data** lines. The **Transport Stream Data Valid** signal informs the decoder that the input is valid.

11.2.5 Decoder Control Signals (Input and Output)

Uart_rx and **Uart_tx** are the API pins for controlling the operations of the decoder. **Uart_rx** receives the command from an external control device. **Uart_tx** send the decoder information to the control device. Refer to the **Uart** standard for details of **Uart** operations. The SOC API User Manual provides the register map for the API control. Refer to the [Decoder API User Manual](#) for details.

11.3 Power Rails of SoM-X-Z7045

The power rails for the H.265 HD decoder module is the same as the ones for the H.265 HD encoder module. Refer to Appendix-C for the power and ground pins on the edge connector of the SoM-X-Z7045 module.

11.4 Power Requirement and Supply Current

The total power at operation required by a given decoder ranges from 3 to 8 Watts, depending on the resolution and frame rate. Since the total power is delivered over 6 power rails, each individual power rail delivers only a portion of the total power. However, the power is not evenly distributed among the rails. Table-19 lists the power estimation for each rail, for PCB design purpose. It should be noted that the estimated total power showing in Table-19 is higher than the real power consumption of the module, the power estimation in Table-19 is for PCB design purpose.

Again, the power rails of 1.8v are generated on the module, using the 2.5v power input from the edge pin. PCB designers need only to design the 6 power rails listed in Table-19.

Table-19: Power estimation for the decoder module (1080p@60 resolution)

| Power Rail | Current (A) | Power (W) |
|------------|-------------|-----------|
| 3.3V | 0.37 | 1.22 |
| 2.5V | 0.99 | 2.48 |
| 1.5V | 1.25 | 1.87 |
| 1.3V | 0.37 | 0.58 |
| 1.2V | 0.75 | 0.90 |
| 1.0V | 3.39 | 3.39 |

Since the decoder module normally shares the power supplies with the carrier board (user PCB), the power design should be considered for both. SOC licenses the schematics of carrier boards, such as the VTR-S1000 and VTR-4000C discussed in Section 19 of this document. The reference designs not only provide the power system design, but also the I/O port designs, such as SDI, HDMI, Mini-USB, etc. Contact SOC sale at: sales@soctechologies.com for further details.

11.5 Booting Sequence and Booting Time

The module design has considered the booting sequence of the FPGA on the module. Therefore, there is no booting sequence requirement by the module for carrier board designs, i.e. the power rails can be supplied to the module at the same time or at any sequence. Once all of the power rails are supplied, the module will start to boot. The booting time is less than 2 seconds.

(Left Empty here intentionally)

12. The H.265 4k@30 Encoder Modules

Note:

The “Pin Assignments and Pin Voltages” of H.265 4k@30 Encoder Module is identical to the “Pin Assignments and Pin Voltages” of H.264 4k@30 Encoder Module detailed in Section 6. However, Pin Assignments and Pin Voltages of H.265 4k@30 Encoder Module is provided here in this Section for completion.

12.1 Pin Assignments and Pin Voltages

The H.265 4k@30 encoder uses the SoM-X-Z7045 module. The pin assignments are the same as the H.264 4k@30 encoder module.

Table-20 lists the pin assignments and the pin voltages for the H.265 4K@30 encoder modules based on the SoM-X-Z7045.

The schematics of SoM-X-Z7045 edge connector are attached in Appendix-C of this document, which shows the pin numbers for data, clock, control, and power.

Table-20 also lists the FPGA pin numbers that are connected to the edge pins assigned to the encoder. The Zynq-7000 datasheet provides further information regarding the properties of these pins, and can be used as a reference.

Table-20: 4K@30 Encoder Module (based on SoM-X-Z7045) Pin Assignment and Pin Voltages

| Description | SoM-X-Z7045 | Edge | Direction | FPGA Pin # | Voltage | IO Standard |
|-----------------------|-------------|------|-----------|------------|---------|-------------|
| PS Soft Reset B | 156 | | Input | B19 | 3.3V | LVC MOS33 |
| Video Clock 0 | 63 | | Input | AC18 | 1.5v | LVC MOS15 |
| Video Clock 1 | 80 | | Input | AF15 | 3.3v | LVC MOS33 |
| Video Clock 2 | 144 | | Input | AE28 | 3.3v | LVC MOS33 |
| Video Clock 3 | 105 | | Input | AG21 | 3.3v | LVC MOS33 |
| Video Horizontal Sync | 133 | | Input | W24 | 1.5v | LVC MOS15 |
| Video Vertical Sync | 113 | | Input | AF22 | 3.3v | LVC MOS33 |
| Video Display Enable | 67 | | Input | AD18 | 1.5v | LVC MOS15 |
| Video Data 0 Luma[0] | 135 | | Input | W25 | 1.5v | LVC MOS15 |
| Video Data 0 Luma[1] | 137 | | Input | W26 | 1.5v | LVC MOS15 |
| Video Data 0 Luma[2] | 116 | | Input | V27 | 1.5v | LVC MOS15 |
| Video Data 0 Luma[3] | 118 | | Input | W28 | 1.5v | LVC MOS15 |
| Video Data 0 Luma[4] | 124 | | Input | W29 | 1.5v | LVC MOS15 |
| Video Data 0 Luma[5] | 126 | | Input | W30 | 1.5v | LVC MOS15 |
| Video Data 0 Luma[6] | 128 | | Input | V28 | 1.5v | LVC MOS15 |
| Video Data 0 Luma[7] | 130 | | Input | V29 | 1.5v | LVC MOS15 |
| Video Data 0 Luma[8] | 132 | | Input | T30 | 1.5v | LVC MOS15 |

| | | | | | |
|------------------------|-----|-------|------|------|-----------|
| Video Data 0 Luma[9] | 134 | Input | U30 | 1.5v | LVC MOS15 |
| Video Data 1 Luma[0] | 117 | Input | AG22 | 3.3v | LVC MOS33 |
| Video Data 1 Luma[1] | 119 | Input | AH22 | 3.3v | LVC MOS33 |
| Video Data 1 Luma[2] | 121 | Input | AJ21 | 3.3v | LVC MOS33 |
| Video Data 1 Luma[3] | 123 | Input | AK21 | 3.3v | LVC MOS33 |
| Video Data 1 Luma[4] | 125 | Input | AF23 | 3.3v | LVC MOS33 |
| Video Data 1 Luma[5] | 127 | Input | AF24 | 3.3v | LVC MOS33 |
| Video Data 1 Luma[6] | 92 | Input | AJ23 | 3.3v | LVC MOS33 |
| Video Data 1 Luma[7] | 94 | Input | AJ24 | 3.3v | LVC MOS33 |
| Video Data 1 Luma[8] | 96 | Input | AG24 | 3.3v | LVC MOS33 |
| Video Data 1 Luma[9] | 98 | Input | AG25 | 3.3v | LVC MOS33 |
| Video Data 2 Luma[0] | 77 | Input | AJ16 | 3.3v | LVC MOS33 |
| Video Data 2 Luma[1] | 79 | Input | AK16 | 3.3v | LVC MOS33 |
| Video Data 2 Luma[2] | 81 | Input | AH17 | 3.3v | LVC MOS33 |
| Video Data 2 Luma[3] | 83 | Input | AH16 | 3.3v | LVC MOS33 |
| Video Data 2 Luma[4] | 85 | Input | AH18 | 3.3v | LVC MOS33 |
| Video Data 2 Luma[5] | 87 | Input | AJ18 | 3.3v | LVC MOS33 |
| Video Data 2 Luma[6] | 78 | Input | AF13 | 3.3v | LVC MOS33 |
| Video Data 2 Luma[7] | 82 | Input | AG15 | 3.3v | LVC MOS33 |
| Video Data 2 Luma[8] | 84 | Input | AG17 | 3.3v | LVC MOS33 |
| Video Data 2 Luma[9] | 86 | Input | AG16 | 3.3v | LVC MOS33 |
| Video Data 3 Luma[0] | 107 | Input | AH21 | 3.3v | LVC MOS33 |
| Video Data 3 Luma[1] | 122 | Input | AH29 | 3.3v | LVC MOS33 |
| Video Data 3 Luma[2] | 115 | Input | AE22 | 3.3v | LVC MOS33 |
| Video Data 3 Luma[3] | 146 | Input | AF28 | 3.3v | LVC MOS33 |
| Video Data 3 Luma[4] | 148 | Input | AF29 | 3.3v | LVC MOS33 |
| Video Data 3 Luma[5] | 150 | Input | AG29 | 3.3v | LVC MOS33 |
| Video Data 3 Luma[6] | 100 | Input | AH23 | 3.3v | LVC MOS33 |
| Video Data 3 Luma[7] | 102 | Input | AH24 | 3.3v | LVC MOS33 |
| Video Data 3 Luma[8] | 104 | Input | AJ25 | 3.3v | LVC MOS33 |
| Video Data 3 Luma[9] | 106 | Input | AK25 | 3.3v | LVC MOS33 |
| Video Data 0 Chroma[0] | 143 | Input | T29 | 1.5v | LVC MOS15 |
| Video Data 0 Chroma[1] | 145 | Input | U29 | 1.5v | LVC MOS15 |
| Video Data 0 Chroma[2] | 147 | Input | R28 | 1.5v | LVC MOS15 |
| Video Data 0 Chroma[3] | 149 | Input | T28 | 1.5v | LVC MOS15 |
| Video Data 0 Chroma[4] | 151 | Input | P30 | 1.5v | LVC MOS15 |
| Video Data 0 Chroma[5] | 153 | Input | R30 | 1.5v | LVC MOS15 |
| Video Data 0 Chroma[6] | 155 | Input | N29 | 1.5v | LVC MOS15 |
| Video Data 0 Chroma[7] | 157 | Input | P29 | 1.5v | LVC MOS15 |
| Video Data 0 Chroma[8] | 159 | Input | N28 | 1.5v | LVC MOS15 |
| Video Data 0 Chroma[9] | 161 | Input | P28 | 1.5v | LVC MOS15 |
| Video Data 1 Chroma[0] | 89 | Input | AK17 | 3.3v | LVC MOS33 |
| Video Data 1 Chroma[1] | 91 | Input | AK18 | 3.3v | LVC MOS33 |
| Video Data 1 Chroma[2] | 93 | Input | AF19 | 3.3v | LVC MOS33 |
| Video Data 1 Chroma[3] | 95 | Input | AG19 | 3.3v | LVC MOS33 |
| Video Data 1 Chroma[4] | 97 | Input | AH19 | 3.3v | LVC MOS33 |
| Video Data 1 Chroma[5] | 99 | Input | AJ19 | 3.3v | LVC MOS33 |
| Video Data 1 Chroma[6] | 101 | Input | AF20 | 3.3v | LVC MOS33 |

| | | | | | |
|-------------------------------|-----|--------|------|------|-----------|
| Video Data 1 Chroma[7] | 103 | Input | AG20 | 3.3v | LVC MOS33 |
| Video Data 1 Chroma[8] | 109 | Input | AJ20 | 3.3v | LVC MOS33 |
| Video Data 1 Chroma[9] | 111 | Input | AK20 | 3.3v | LVC MOS33 |
| Video Data 2 Chroma[0] | 38 | Input | AE12 | 3.3v | LVC MOS33 |
| Video Data 2 Chroma[1] | 40 | Input | AF12 | 3.3v | LVC MOS33 |
| Video Data 2 Chroma[2] | 50 | Input | AG12 | 3.3v | LVC MOS33 |
| Video Data 2 Chroma[3] | 52 | Input | AH12 | 3.3v | LVC MOS33 |
| Video Data 2 Chroma[4] | 54 | Input | AH14 | 3.3v | LVC MOS33 |
| Video Data 2 Chroma[5] | 56 | Input | AH13 | 3.3v | LVC MOS33 |
| Video Data 2 Chroma[6] | 58 | Input | AJ14 | 3.3v | LVC MOS33 |
| Video Data 2 Chroma[7] | 60 | Input | AJ13 | 3.3v | LVC MOS33 |
| Video Data 2 Chroma[8] | 59 | Input | AK13 | 3.3v | LVC MOS33 |
| Video Data 2 Chroma[9] | 61 | Input | AK12 | 3.3v | LVC MOS33 |
| Video Data 3 Chroma[0] | 108 | Input | AJ26 | 3.3v | LVC MOS33 |
| Video Data 3 Chroma[1] | 110 | Input | AK26 | 3.3v | LVC MOS33 |
| Video Data 3 Chroma[2] | 112 | Input | AH26 | 3.3v | LVC MOS33 |
| Video Data 3 Chroma[3] | 114 | Input | AH27 | 3.3v | LVC MOS33 |
| Video Data 3 Chroma[4] | 136 | Input | AK27 | 3.3v | LVC MOS33 |
| Video Data 3 Chroma[5] | 138 | Input | AK28 | 3.3v | LVC MOS33 |
| Video Data 3 Chroma[6] | 139 | Input | AJ28 | 3.3v | LVC MOS33 |
| Video Data 3 Chroma[7] | 141 | Input | AJ29 | 3.3v | LVC MOS33 |
| Video Data 3 Chroma[8] | 140 | Input | AJ30 | 3.3v | LVC MOS33 |
| Video Data 3 Chroma[9] | 142 | Input | AK30 | 3.3v | LVC MOS33 |
| SPDIF Audio | 27 | Input | Y20 | 1.5v | LVC MOS15 |
| Transport Stream Buffer Ready | 29 | Input | AA20 | 1.5v | LVC MOS15 |
| Transport Stream Clock | 31 | Output | AA18 | 1.5v | LVC MOS15 |
| Transport Stream Data Valid | 33 | Output | AA19 | 1.5v | LVC MOS15 |
| Transport Stream Data [0] | 152 | Output | AF30 | 3.3v | LVC MOS33 |
| Transport Stream Data [1] | 154 | Output | AG30 | 3.3v | LVC MOS33 |
| Transport Stream Data [2] | 158 | Output | AE30 | 3.3v | LVC MOS33 |
| Transport Stream Data [3] | 160 | Output | AB29 | 3.3v | LVC MOS33 |
| Transport Stream Data [4] | 162 | Output | AB30 | 3.3v | LVC MOS33 |
| Transport Stream Data [5] | 164 | Output | AA27 | 3.3v | LVC MOS33 |
| Transport Stream Data [6] | 166 | Output | AA28 | 3.3v | LVC MOS33 |
| Transport Stream Data [7] | 120 | Output | AH28 | 3.3v | LVC MOS33 |
| Uart_tx | 90 | Output | AK15 | 3.3v | LVC MOS33 |
| Uart_rx | 88 | Input | AJ15 | 3.3v | LVC MOS33 |

12.2 Signal Formats

12.2.1 Clock Signals (Input)

The 4k@30 encoder has 4 input clocks, **Video Clock 0** (pin #63), **Video Clock 1** (pin #80), **Video Clock 2** (pin #144), and **Video Clock 3** (pin #105). These clocks match the four of 3G SDI inputs for one 4k@30 video. The clock rate is 74.25 MHz, and the video data are sampled at dual data rate, at both the rising and falling edges of the clock.

However, if one 4k input is used on the carrier board, such as HDMI 1.4/2.0 or 6/12G SDI, only **Video Clock 0** is needed which is also 74.25 MHz, with dual data rate as well.

12.2.2 Video Data Signals (Input)

The input to the encoder module is raw video data in YUV format (4:2:2 or 4:2:0), with 40 input lines: **Video Data 0 Luma[0]** to **Video Data 3 Luma[9]**, for Luma; and, 40 input lines: **Video Data 0 Chroma[0]** to **Video Data 3 Chroma[9]**, for the Chroma. The precision is either 8 bits or 10 bits. For 8-bit precision, the Most Significant Luma and Chroma pins (Luma[2] to Luma[9], Chroma[2] to Chroma[9]) are used.

In addition to the video Luma and Chroma data signals, the **Video Horizontal Sync** and **Video Vertical Sync** signals are required for frame synchronization if embedded SAV/EAV are not used. The video clocks (refer to Section 12.2.1) provide the timing for the parallel input of luma, chroma, as well as the **Video Horizontal Sync** and **Video Vertical Sync** signals. The **Video Display Enable** signal is a part of the **Video Horizontal Sync** and **Video Vertical Sync** system, where high signal indicates active video pixels. For example, an HDMI input interface chip will output the **Video Display Enable** signal at high, when active pixels are being sent out.

The video data are sampled at the rising edge of the clock. The clock rates will correspond to the resolution and frame rate, as discussed in Section 12.2.1.

12.2.3 Audio Data Signals (Input)

Input line **SPDIF Audio** is for PCM audio input, in **SPDIF** frames. An **SPDIF** transmitter is required to send the PCM data to the encoder module. Refer to the **SPDIF** protocol documents for details.

12.2.4 TS stream Signals (Output)

The output of the encoder module is MPEG Transport Stream (TS), which is sent out from the module by 8 parallel lines: **Transport Stream Data[0]** to **Transport Stream Data[7]**, along with the Transport Stream output data clock **Transport Stream Clock** (pin # 31). The frequency of the Transport Stream Data clock is 27MHz.

Transport Stream Buffer Ready (pin # 29) and **Transport Stream Data Valid** (pin # 33) are the signals to inform the user side to take over the signals.

12.2.5 Encoder Control Signals (Input and Output)

Uart_rx and **Uart_tx** are the API pins for controlling the operations of the encoder. **Uart_rx** receives the command from external control device. **Uart_tx** sends the encoder information to the control device. Refer to the **Uart** standard for details of **Uart** operations. The SOC API User Manual provides the register map for the API control. Refer to the [Encoder API User Manual](#) for more details.

An external reset **PS Soft Reset_B** (pin # 156) is available. This pin allows the user to reset the encoder when necessary. A low signal will trigger a reset. The reset signal should be maintained at high or left unconnected when in normal operation mode.

12.3 Power Rails of SoM-X-Z7045

Refer to Appendix-B for the pins of power and ground on the edge connector of the SoM-X-Z7045 module. The power rails are: 1.0V, 1.2V, 1.3V, 1.5V, 2.5V, and 3.3V.

12.4 Power Requirement and Supply Current

The total power, at operation, required by a given encoder module ranges from 3 to 6 watts, depending on the resolution and frame rate. Since the total power is delivered over 6 power rails (1.0v, 1.2v, 1.3v, 1.5v, 2.5v, and 3.3v), each individual power rails deliveries only a portion of the total power. However, the power is not evenly distributed among the rails. Table-21 lists the power estimations for each rail, at 4k@30 resolution, which can be for PCB design purpose. It should be noted that the estimated total power showing in Table-21 is higher than the real power consumption of the module, as it is for PCB design purposes. It should also be noted that the power rails 1.8v and 2.0v are generated on the module, by using some of the input power rails. Carrier board PCB designers need not to consider these two rails.

Table-21: Power estimation for the H.265 4k@30 encoder module

| Power Rail | Current (A) | Power (W) |
|------------|-------------|-----------|
| 3.3V | 0.50 | 1.63 |
| 2.5V | 1.34 | 3.34 |
| 1.5V | 0.96 | 1.44 |
| 1.3V | 0.03 | 0.38 |
| 1.2V | 0.24 | 0.29 |
| 1.0V | 5.76 | 5.76 |

Since the encoder module normally shares the power supplies with the carrier board (user PCB). The power design should be considered for both the module and the carrier board. SOC licenses the schematics of carrier boards. The VTR-4000C discussed in Section 19 of this document is for 4k resolution. The reference design provides not only the power system design, but also the I/O port designs, such as SDI, HDMI, Mini-USB, etc. Contact SOC sale at: sales@soctechnologies.com for design licensing information.

12.5 Booting Sequence and Booting Time

The module design has considered the booting sequence of the FPGA on the module. Therefore, there is no booting sequence requirement by the module for carrier board designs, i.e. the power rails can be supplied to the module at the same time or at any sequence. Once all of the power rails are supplied, the module will start to boot. The booting time is less than 2 seconds.

13. The H.265 4K@30 Decoder Modules

Note:

The “Pin Assignments and Pin Voltages” of H.265 4k@30 Decoder Module is identical to the “Pin Assignments and Pin Voltages” of H.264 4k@30 Decoder Module detailed in Section 7. However, Pin Assignments and Pin Voltages of H.265 4k@30 Decoder Module it is provided here in this Section for completion.

13.1 Pin Assignments and Pin Voltages

The H.265 4K@30 decoder uses the SoM-X-Z45. The pin assignment is the same as the H.264 4K@30 decoder. This section provides again the pin assignment and pin voltages for H.265 4K@30 decoder modules based on the SoM-X-Z7045.

Table-22 shows the pin assignments and the pin voltages for H.265 4k@30 decoder modules based on the SoM-X-Z45.

The schematics of SoM-X-Z7045 edge connector are attached in Appendix-C of this document. Appendix-C shows the pin numbers for data, clock, control, and power, which are connected to the FPGA.

It should be noted that the H.265 4K@30 encoder and decoder pin assignments are symmetrical, i.e. the video input pins on the encoder module become the video output pins on the decoder module.

Table-22: 4K@30 Decoder Module (based on SoM-X-Z7045) Pin Assignment

| Description | SoM-X-Z7045 Edge Connector Pin # | Direction | FPGA Pin # | Voltage | IO Standard |
|-----------------------|----------------------------------|-----------|------------|---------|-------------|
| PS Soft Reset_B | 156 | Input | B19 | 3.3V | LVC MOS33 |
| Video Clock | 105 | Output | AG21 | 3.3v | LVC MOS33 |
| Video Horizontal Sync | 133 | Output | W24 | 1.5v | LVC MOS15 |
| Video Vertical Sync | 113 | Output | AF22 | 3.3v | LVC MOS33 |
| Video Display Enable | 67 | Output | AD18 | 1.5v | LVC MOS15 |
| Video Data 0 Luma[0] | 135 | Output | W25 | 1.5v | LVC MOS15 |
| Video Data 0 Luma[1] | 137 | Output | W26 | 1.5v | LVC MOS15 |
| Video Data 0 Luma[2] | 116 | Output | V27 | 1.5v | LVC MOS15 |
| Video Data 0 Luma[3] | 118 | Output | W28 | 1.5v | LVC MOS15 |
| Video Data 0 Luma[4] | 124 | Output | W29 | 1.5v | LVC MOS15 |
| Video Data 0 Luma[5] | 126 | Output | W30 | 1.5v | LVC MOS15 |
| Video Data 0 Luma[6] | 128 | Output | V28 | 1.5v | LVC MOS15 |
| Video Data 0 Luma[7] | 130 | Output | V29 | 1.5v | LVC MOS15 |
| Video Data 0 Luma[8] | 132 | Output | T30 | 1.5v | LVC MOS15 |
| Video Data 0 Luma[9] | 134 | Output | U30 | 1.5v | LVC MOS15 |
| Video Data 1 Luma[0] | 117 | Output | AG22 | 3.3v | LVC MOS33 |

| | | | | | |
|------------------------|-----|--------|------|------|-----------|
| Video Data 1 Luma[1] | 119 | Output | AH22 | 3.3v | LVC MOS33 |
| Video Data 1 Luma[2] | 121 | Output | AJ21 | 3.3v | LVC MOS33 |
| Video Data 1 Luma[3] | 123 | Output | AK21 | 3.3v | LVC MOS33 |
| Video Data 1 Luma[4] | 125 | Output | AF23 | 3.3v | LVC MOS33 |
| Video Data 1 Luma[5] | 127 | Output | AF24 | 3.3v | LVC MOS33 |
| Video Data 1 Luma[6] | 92 | Output | AJ23 | 3.3v | LVC MOS33 |
| Video Data 1 Luma[7] | 94 | Output | AJ24 | 3.3v | LVC MOS33 |
| Video Data 1 Luma[8] | 96 | Output | AG24 | 3.3v | LVC MOS33 |
| Video Data 1 Luma[9] | 98 | Output | AG25 | 3.3v | LVC MOS33 |
| Video Data 2 Luma[0] | 77 | Output | AJ16 | 3.3v | LVC MOS33 |
| Video Data 2 Luma[1] | 79 | Output | AK16 | 3.3v | LVC MOS33 |
| Video Data 2 Luma[2] | 81 | Output | AH17 | 3.3v | LVC MOS33 |
| Video Data 2 Luma[3] | 83 | Output | AH16 | 3.3v | LVC MOS33 |
| Video Data 2 Luma[4] | 85 | Output | AH18 | 3.3v | LVC MOS33 |
| Video Data 2 Luma[5] | 87 | Output | AJ18 | 3.3v | LVC MOS33 |
| Video Data 2 Luma[6] | 78 | Output | AF13 | 3.3v | LVC MOS33 |
| Video Data 2 Luma[7] | 82 | Output | AG15 | 3.3v | LVC MOS33 |
| Video Data 2 Luma[8] | 84 | Output | AG17 | 3.3v | LVC MOS33 |
| Video Data 2 Luma[9] | 86 | Output | AG16 | 3.3v | LVC MOS33 |
| Video Data 3 Luma[0] | 107 | Output | AH21 | 3.3v | LVC MOS33 |
| Video Data 3 Luma[1] | 122 | Output | AH29 | 3.3v | LVC MOS33 |
| Video Data 3 Luma[2] | 115 | Output | AE22 | 3.3v | LVC MOS33 |
| Video Data 3 Luma[3] | 146 | Output | AF28 | 3.3v | LVC MOS33 |
| Video Data 3 Luma[4] | 148 | Output | AF29 | 3.3v | LVC MOS33 |
| Video Data 3 Luma[5] | 150 | Output | AG29 | 3.3v | LVC MOS33 |
| Video Data 3 Luma[6] | 100 | Output | AH23 | 3.3v | LVC MOS33 |
| Video Data 3 Luma[7] | 102 | Output | AH24 | 3.3v | LVC MOS33 |
| Video Data 3 Luma[8] | 104 | Output | AJ25 | 3.3v | LVC MOS33 |
| Video Data 3 Luma[9] | 106 | Output | AK25 | 3.3v | LVC MOS33 |
| Video Data 0 Chroma[0] | 143 | Output | T29 | 1.5v | LVC MOS15 |
| Video Data 0 Chroma[1] | 145 | Output | U29 | 1.5v | LVC MOS15 |
| Video Data 0 Chroma[2] | 147 | Output | R28 | 1.5v | LVC MOS15 |
| Video Data 0 Chroma[3] | 149 | Output | T28 | 1.5v | LVC MOS15 |
| Video Data 0 Chroma[4] | 151 | Output | P30 | 1.5v | LVC MOS15 |
| Video Data 0 Chroma[5] | 153 | Output | R30 | 1.5v | LVC MOS15 |
| Video Data 0 Chroma[6] | 155 | Output | N29 | 1.5v | LVC MOS15 |
| Video Data 0 Chroma[7] | 157 | Output | P29 | 1.5v | LVC MOS15 |
| Video Data 0 Chroma[8] | 159 | Output | N28 | 1.5v | LVC MOS15 |
| Video Data 0 Chroma[9] | 161 | Output | P28 | 1.5v | LVC MOS15 |
| Video Data 1 Chroma[0] | 89 | Output | AK17 | 3.3v | LVC MOS33 |
| Video Data 1 Chroma[1] | 91 | Output | AK18 | 3.3v | LVC MOS33 |
| Video Data 1 Chroma[2] | 93 | Output | AF19 | 3.3v | LVC MOS33 |
| Video Data 1 Chroma[3] | 95 | Output | AG19 | 3.3v | LVC MOS33 |

| | | | | | |
|-----------------------------|-----|--------|------|------|-----------|
| Video Data 1 Chroma[4] | 97 | Output | AH19 | 3.3v | LVC MOS33 |
| Video Data 1 Chroma[5] | 99 | Output | AJ19 | 3.3v | LVC MOS33 |
| Video Data 1 Chroma[6] | 101 | Output | AF20 | 3.3v | LVC MOS33 |
| Video Data 1 Chroma[7] | 103 | Output | AG20 | 3.3v | LVC MOS33 |
| Video Data 1 Chroma[8] | 109 | Output | AJ20 | 3.3v | LVC MOS33 |
| Video Data 1 Chroma[9] | 111 | Output | AK20 | 3.3v | LVC MOS33 |
| Video Data 2 Chroma[0] | 38 | Output | AE12 | 3.3v | LVC MOS33 |
| Video Data 2 Chroma[1] | 40 | Output | AF12 | 3.3v | LVC MOS33 |
| Video Data 2 Chroma[2] | 50 | Output | AG12 | 3.3v | LVC MOS33 |
| Video Data 2 Chroma[3] | 52 | Output | AH12 | 3.3v | LVC MOS33 |
| Video Data 2 Chroma[4] | 54 | Output | AH14 | 3.3v | LVC MOS33 |
| Video Data 2 Chroma[5] | 56 | Output | AH13 | 3.3v | LVC MOS33 |
| Video Data 2 Chroma[6] | 58 | Output | AJ14 | 3.3v | LVC MOS33 |
| Video Data 2 Chroma[7] | 60 | Output | AJ13 | 3.3v | LVC MOS33 |
| Video Data 2 Chroma[8] | 59 | Output | AK13 | 3.3v | LVC MOS33 |
| Video Data 2 Chroma[9] | 61 | Output | AK12 | 3.3v | LVC MOS33 |
| Video Data 3 Chroma[0] | 108 | Output | AJ26 | 3.3v | LVC MOS33 |
| Video Data 3 Chroma[1] | 110 | Output | AK26 | 3.3v | LVC MOS33 |
| Video Data 3 Chroma[2] | 112 | Output | AH26 | 3.3v | LVC MOS33 |
| Video Data 3 Chroma[3] | 114 | Output | AH27 | 3.3v | LVC MOS33 |
| Video Data 3 Chroma[4] | 136 | Output | AK27 | 3.3v | LVC MOS33 |
| Video Data 3 Chroma[5] | 138 | Output | AK28 | 3.3v | LVC MOS33 |
| Video Data 3 Chroma[6] | 139 | Output | AJ28 | 3.3v | LVC MOS33 |
| Video Data 3 Chroma[7] | 141 | Output | AJ29 | 3.3v | LVC MOS33 |
| Video Data 3 Chroma[8] | 140 | Output | AJ30 | 3.3v | LVC MOS33 |
| Video Data 3 Chroma[9] | 142 | Output | AK30 | 3.3v | LVC MOS33 |
| SPDIF Audio | 27 | Output | Y20 | 1.5v | LVC MOS15 |
| Transport Stream Clock | 31 | Input | AA18 | 1.5v | LVC MOS15 |
| Transport Stream Data Valid | 33 | input | AA19 | 1.5v | LVC MOS15 |
| Transport Stream Data [0] | 152 | input | AF30 | 3.3v | LVC MOS33 |
| Transport Stream Data [1] | 154 | input | AG30 | 3.3v | LVC MOS33 |
| Transport Stream Data [2] | 158 | input | AE30 | 3.3v | LVC MOS33 |
| Transport Stream Data [3] | 160 | input | AB29 | 3.3v | LVC MOS33 |
| Transport Stream Data [4] | 162 | input | AB30 | 3.3v | LVC MOS33 |
| Transport Stream Data [5] | 164 | input | AA27 | 3.3v | LVC MOS33 |
| Transport Stream Data [6] | 166 | input | AA28 | 3.3v | LVC MOS33 |
| Transport Stream Data [7] | 120 | input | AH28 | 3.3v | LVC MOS33 |
| Uart_tx | 90 | Output | AK15 | 3.3v | LVC MOS33 |
| Uart_rx | 88 | Input | AJ15 | 3.3v | LVC MOS33 |

13.2 Signal Formats

13.2.1 Video Clock Signal (Output)

The Decoder Clock signal is an input clock for driving the decoder engine. When an SDI port on the carrier board is used to send out the decoded video data, the SDI clock can be connected to the Decoder Clock. This will automatically synchronize the decoder outputs with the SDI interface. The SDI clock frequency is 74.25MHz, for 4K@30.

13.2.2 Video Data Signals (Output)

The output of the H.264 4k@30 decoder module is the decoded video data in YUV format (4:2:2 or 4:2:0), with 40 output lines: **Video Data 0 Luma[0]** to **Video Data 3 Luma[9]**, for Luma, and, 40 lines: **Video Data 0 Chroma[0]** to **Video Data 3 Chroma[9]**, for the Chroma. The precision can be either 8-bit precision or 10-bit precision. For 8-bit precision, the Most Significant Bits of luma and chroma output lines (Luma[2] to Luma[9], Chroma[2] to Chroma[9]) are used.

In addition to the video Luma and Chroma data signals, the **Video Horizontal Sync** and **Video Vertical Sync** signals are provided for frame synchronization. The **Video Display Enable signal** is a part of the **Video Horizontal Sync** and **Video Vertical Sync** system, where high signal indicates active video pixels.

13.2.3 Audio Data Signals (Output)

Line **SPDIF Audio** is for PCM audio output, in **SPDIF** frames. An **SPDIF** transmitter is included in the module to send the PCM data out via the decoder edge pins. Refer to the **SPDIF** protocol documents for details.

13.2.4 Decoder Control Signals (Input and output)

Uart_rx and **Uart_tx** are the API pins for controlling the operations of the decoder. **Uart_rx** receives the command from an external control device. **Uart_tx** send the decoder information to the control device. Refer to the **Uart** standard for details of **Uart** operations. The SOC API User Manual provides the register map for the API control. Refer to the [Decoder API User Manual](#) for details.

13.3 Power Rails of SoM-X-Z7045

The power rails for H.265 4k@30 decoder are the same as the H.264 4k@30 encoder. Refer to Appendix-C for the pins of power and ground on the edge connector of the SoM-X-Z7045 module.

13.4 Power Requirement and Supply Current

Since the total power is delivered over 6 power rails (1.0v, 1.2v, 1.3v, 1.5v, 2.5v, and 3.3v), each individual power rails deliveries only a portion of the total power. However, the power is not evenly distributed among the rails. Table-23 lists the power estimations for each rail, at 4k@30 resolution, which can be used for PCB designs for the

4k@30 module. It should be noted that the power rails 1.8v and 2.0v are generated on the module using the input power rails. PCB designers for the carrier boards need not to consider these two rails.

Since the decoder module normally shares the power supplies with the carrier board (user PCB). The power design should be considered for both. SOC licenses the schematics of carrier boards. The VTR-4000C, discussed in Section 19 of this document, is for 4k resolution. The reference designs not only provide the power system design, but also the I/O port designs, such as SDI, HDMI, Mini-USB, etc. Please contact SOC sale at: sales@soctechnologies.com for further details.

Table-23: Power estimation for the H.265 4K@30 decoder module

| Power Rail | Current (A) | Power (W) |
|------------|-------------|-----------|
| 3.3V | 0.50 | 1.64 |
| 2.5V | 1.34 | 3.36 |
| 1.5V | 0.96 | 1.44 |
| 1.3V | 0.30 | 0.40 |
| 1.2V | 0.24 | 0.29 |
| 1.0V | 5.76 | 5.76 |

13.5 Booting Sequence and Booting Time

The module design has considered the booting sequence of the FPGA on the module. Therefore, there is no booting sequence requirement by the module for carrier board designs, i.e. the power rails can be supplied to the module at the same time or at any sequence. Once all of the power rails are supplied, the module will start to boot. The booting time is less than 2 seconds.

(Left Empty here intentionally)

14. The H.265 4k@60 Encoder Modules

To be added

15. The H.265 4K@60 Decoder Modules

To be added

(Left Empty here intentionally)

16. The H.264-to-MPEG2 HD Transcoder Module

16.1 Pin Assignments and Pin Voltages

The SOC Transcoder IP cores are “full decoding plus re-encoding”, based on the SOC decoder and encoder IP cores. The H.264-to-MPEG2 Transcoder is a core combining the SOC H.264 decoder and the SOC MPEG-2 encoder, which achieves the best transcoding quality.

The HD (1080@30 and 1080@60) transcoder module from H.264 to MPEG-2 uses the SoM-X-A200T (the Artix-7 A200T FPGA), and the SOC H.264-to-MPEG2 Transcoder IP core.

This Section provides the pin assignments and pin voltages for the H.264-to-MPEG2 transcoder module based on the SoM-X-A200T are provided in Table-24.

The schematics of SoM-X-A200T edge connector are attached in Appendix-B of this document, which shows the pin numbers for data, clock, control, and power. It should be noted that the encoder module uses only some of the edge pins, and not all of the edge pins are used.

Table 24: HD Encoder Module (based on SoM-X-A200T) Pin Assignment and Pin Voltages

| Description | SoM-X-A200T Edge Connector Pin # | Direction | Voltage |
|-------------|----------------------------------|-----------|---------|
| TS_CLK | 105 | input | 3v3 |
| TS_DATA7 | 157 | input | 3v3 |
| TS_DATA6 | 155 | input | 3v3 |
| TS_DATA5 | 153 | input | 3v3 |
| TS_DATA4 | 151 | input | 3v3 |
| TS_DATA3 | 149 | input | 3v3 |
| TS_DATA2 | 147 | input | 3v3 |
| TS_DATA1 | 145 | input | 3v3 |
| TS_DATA0 | 143 | input | 3v3 |
| TS_DV | 159 | input | 3v3 |
| | | | |
| TS_CLK | 146 | Output | 3v3 |
| TS_DATA7 | 156 | Output | 3v3 |
| TS_DATA6 | 166 | Output | 3v3 |
| TS_DATA5 | 164 | Output | 3v3 |
| TS_DATA4 | 162 | Output | 3v3 |
| TS_DATA3 | 160 | Output | 3v3 |
| TS_DATA2 | 158 | Output | 3v3 |
| TS_DATA1 | 154 | Output | 3v3 |
| TS_DATA0 | 152 | Output | 3v3 |
| TS_DV | 148 | Output | 3v3 |
| TS_RDY | 150 | Output | 3v3 |

16.2 Signal Formats

16.2.1 Clock Signal (Input)

The TS_CLK signal (pin # 105) has two functions: (1) It is the clock for the input video data, and (2) it is the clock that drives the transcoder engine.

16.2.2 Input TS stream Signals

The input of the transcoder module is MPEG Transport Stream (TS), which is sent into the module by 8 parallel lines: TS_DATA0 to TS_DATA7, along with the data valid signal TS_DV.

16.2.3 Output TS stream Signals

The output of the transcoder module is MPEG Transport Stream (TS), which is sent out from the module by 8 parallel lines: TS_DATA0 to TS_DATA7, along with the data valid signal TS_DV and the data ready signal TS_RDY.

16.3 Power Rails of SoM-X-A200T

The power rails for the HD (H.264 or MPEG-2) H.264-to-MPEG2 transcoder module is the same as the ones for the HD encoder module. Refer to Table-2 for the power and ground pins. Also, refer to Appendix-B for the power and ground pins on the edge connector of the SoM-X-A200T module.

16.4 Power Requirement and Supply Current

In the transcoder case, the power consumption is the total power of the decoder and the encoder. Refer to **Section 5** for the H.264 HD decoder power and **Section 4** for the MPEG-2 encoder power.

Since the transcoder module normally shares the power supplies with the carrier board (user PCB). The power design should be considered for both. SOC licenses the schematics of carrier boards, such as the VTR-S1000 and VTR-4000C discussed in Section 19 of this document. The reference designs provide not only the power system design and clock distributions, but also the I/O port designs, such as SDI, HDMI, Mini-USB, etc. Please contact SOC sale at: sales@soctechnologies.com for design licensing details.

(Left Empty here intentionally)

17. The MPEG2-to-H.264 HD Transcoder Module

The Pin assignment, pin voltages, and the power of the MPEG2-to-H.264 Transcoder are identical to those of the H.264-to-MPEG2 Transcoder.

(Left Empty here intentionally)

18. The H.264-to-H.265 HD and 4k@30 Transcoder Module

On request

19. Carrier Boards and Evaluation Kits

19.1 Overview of SOC Carrier Boards and Evaluation Kits

SOC has several boards that have the connector for the SOC SoMs and Codec Modules. A carrier board combined with a generic SoM can be used for product development of user SoMs, in which case the users develop their own firmware to make the generic SOMs into their own products.

The carrier boards combined with the SOC codec SOMs become evaluation kits for the SOC Codec Modules. Since the SOC Codec Modules are based on the SOC codec IP cores, the evaluation kits are also used for evaluation of both the SOC codec modules and IP cores. The eval kits can also be used as product development platforms.

19.2 VTR-S1000 Carrier Board

Fig. 11 shows a photo of the VTR-S1000 board. Major components and I/O ports are marked in the figure. Refer to the [User Guide of VTR -S1000](#) for further details.

SOC licenses the Schematics of VTR-S1000 to the customers that have purchased the eval kit VTR-S1000 and encoder (or decoder) Modules. Firmware of the VTR-S1000, including I/O drivers and network IP core, is also available for licensing. Please contact SOC sales, sales@soctechnologies.com, for details.

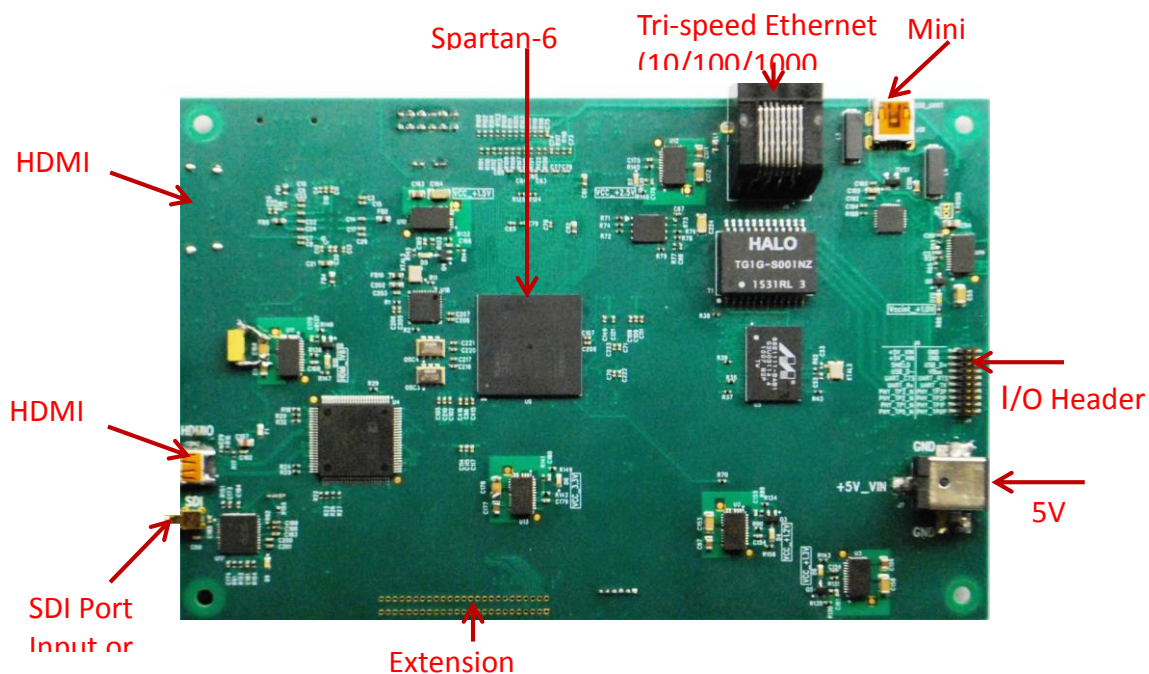

Fig. 11. VTR-S1000 carrier board

19.3 VTR-4000C Carrier Board

Fig. 12 shows the top view of the VTR-4000C board. Major components and I/O ports are marked in the figure. Refer to the [User Guide of VTR-4000C](#) for further details.

SOC licenses the Schematics of VTR-4000C to the customers that have purchased encoder (or decoder) Modules. Firmware of the VTR-4000C, including I/O drivers and network IP core, is also available for licensing. Please contact SOC sales, sales@soctechnologies.com, for details.

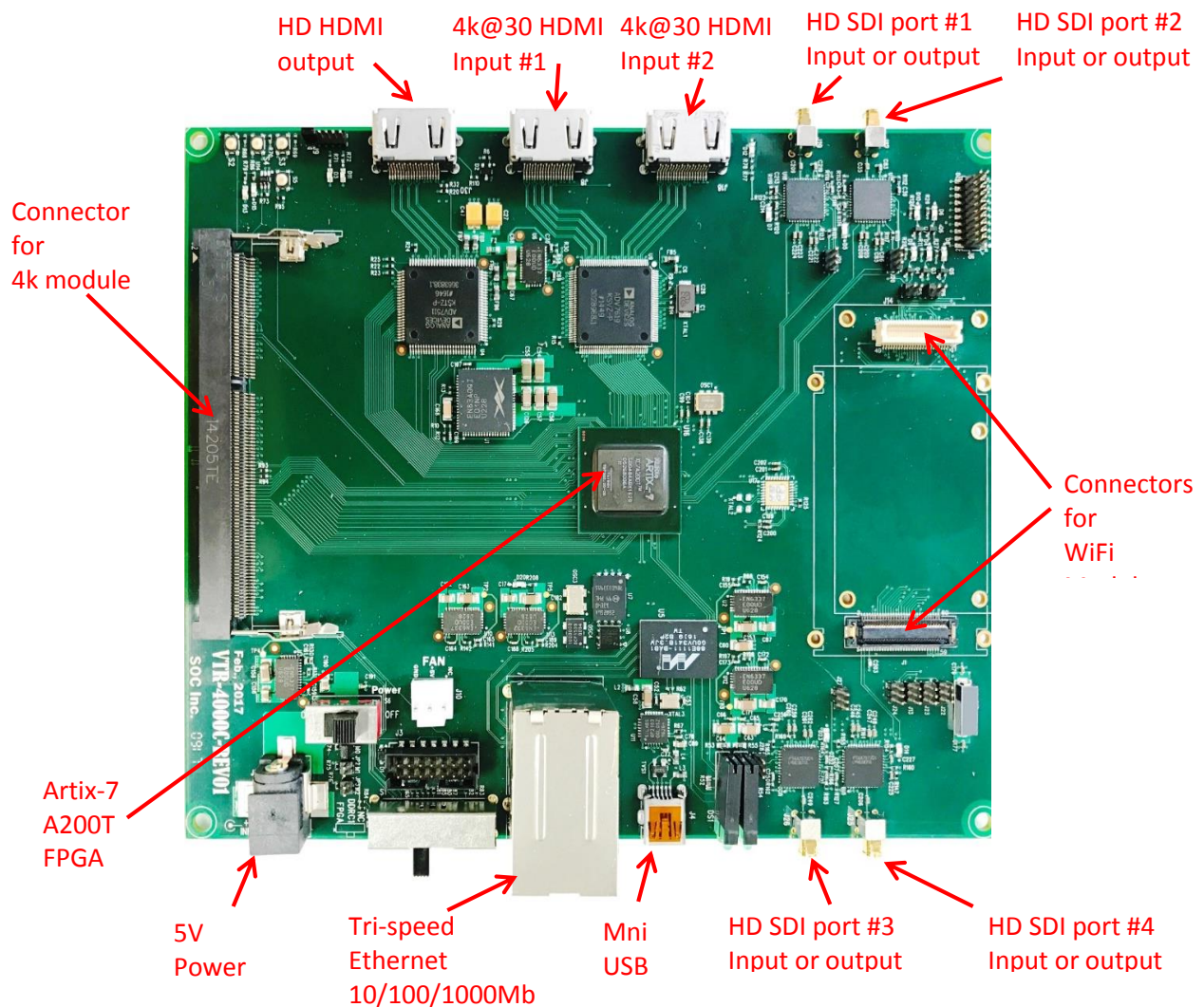

Fig. 12. VTR-4000C carrier board top view

19.4 VoIP-X-4K Carrier Board

Fig. 13 shows the top view of the VoIP-X-4K board. Major components and I/O ports are marked in the figure. Refer to the [User Guide of VoIP-X-4K](#) for further details.

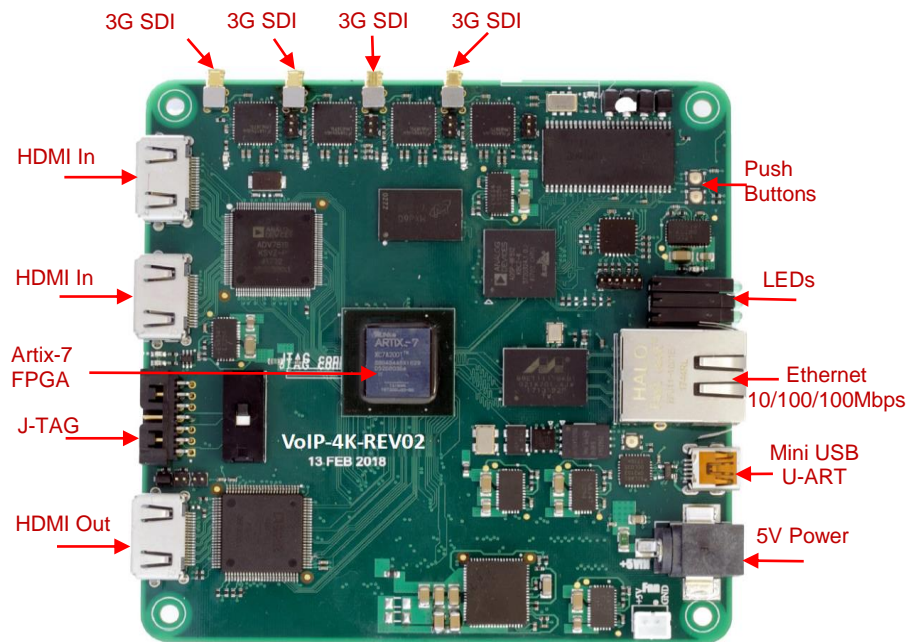

Fig. 13. VoIP-X-4K Carrier board top view

SOC licenses the Schematics of VoIP-X-4K to the customers that have purchased encoder (or decoder) Modules. Firmware of the VoIP-X-4K, including I/O drivers and network IP core, is also available for licensing. Please contact SOC sales, sales@soctechologies.com, for details.

19.5 The Codec Module Evaluation Kits

The Carrier boards described in the above Sections 19.2, 19.3, and 19.4 are used to evaluate the SOC codec modules, codec IP cores, or chipsets. For each codec module listed in Appendix-A, an evaluation kit is available, which consists the codec module and a carrier board. The product code of the Evaluation Kit is the same as the codec module, except the letter “M” is replaced by “EV” which means Evaluation kit. It is note that the SOC codec modules chipset are based on the same IP cores of SOC.

20. Ordering Information

20.1 Ordering of SOC Generic SoMs

Fig. 6 shows the product code system for the SOC SoM modules. Customer can order SoMs using the Product Code listed in Table-2.

20.2 Ordering of SOC Codec Modules

Fig. 7 shows the product code naming convention for the SOC MPEG codec modules, IP cores, and chipsets. Customers can order the SOC codec modules listed in Appendix-A. Non-standard codec modules can be ordered following the same naming format (minimum order quantity is required for non-standard modules).

20. Contact Information

Please contact SOC head office or distributor for product details and to place an order.

Head Office

System-On-Chip (SOC) Technologies Inc.

86 Rankin Street

Waterloo, ON, Canada N2V 1V9

Telephone: 1-519-880-8609

E-mail: sales@soctechnologies.com

21. Document Revisions

| Version # | Revision Date | Notes |
|-----------|---------------|----------------------------|
| V.1.0 | 10/05/2017 | First release |
| V.1.1 | 19/05/2017 | Minor revision |
| V.2.0 | 20/05/2017 | Major revision (adding 4k) |
| V.2.1 | 05/06/2017 | Minor revision |
| V.2.2 | 10/10/2017 | Minor revision |
| V.3.0 | 01/06/2018 | Major revision |
| V.4.0 | 15/05/2019 | Major revision |

Appendix-A Factory Standard Codec Modules

Note:

It is noted that the Temperature and Latency Grade identifiers are not included in the Codec Module product code in the tables. These identifiers are optional, which can be added in the customer orders. The temperature identifier can be either “C” for Commercial Temperature or “I” for Industrial Temperature. The Latency Identifier can be “ZL” for Zero Latency, “LL” for Low Latency, or “SL” for Standard Latency. These latencies are: “ZL” = 0.25ms, “LL” = 1 Frame latency, and “SL” = 2 Frame latency.

A.1 H.264 HD (720@30, 720@60,1080@30, and 1080@60) Encoder Modules

Table-A.1-1 provides a list of standard H.264 HD video (without audio) Encoder Modules. Table-A.1-2 provides a list of standard H.264 HD video&audio Encoder Modules. The product code, specifications, and the SoM hardware are detailed in the table.

Table-A.1-1: H.264 HD Video Encoder Modules (video only without audio):

| Product # | Specifications | | | | | | | SoM |
|-------------------------|----------------|------------|---------------|-------------|---------------|-------------|-------|-------------|
| | Standard | Profile | Resolution | Chroma | Precision | Frame Rate | Audio | |
| EC-V-H264-8b-30-720-M | H.264 | up to High | up to 720i/p | 4:2:0/4:2:2 | 8 bits | up to 30fps | no | SoM-X-A200T |
| EC-V-H264-8b-60-720-M | H.264 | up to High | up to 720i/p | 4:2:0/4:2:2 | 8 bits | up to 60fps | no | SoM-X-A200T |
| EC-V-H264-8b-30-1080-M | H.264 | up to High | up to 1080i/p | 4:2:0/4:2:2 | 8 bits | up to 30fps | no | SoM-X-A200T |
| EC-V-H264-10b-30-1080-M | H.264 | up to High | up to 1080i/p | 4:2:0/4:2:2 | up to 10 bits | up to 30fps | no | SoM-X-A200T |
| EC-V-H264-8b-60-1080-M | H.264 | up to High | up to 1080i/p | 4:2:0/4:2:2 | 8 bits | up to 60fps | no | SoM-X-A200T |
| EC-V-H264-10b-60-1080-M | H.264 | up to High | up to 1080i/p | 4:2:0/4:2:2 | up to 10 bits | up to 60fps | no | SoM-X-A200T |

Table-A.1-2: H.264 HD Video/Audio Encoder Modules (both video and audio):

| Product # | Specifications | | | | | | | SoM |
|--------------------------|----------------|------------|---------------|-------------|---------------|-------------|-------|-------------|
| | Standard | Profile | Resolution | Chroma | Precision | Frame Rate | Audio | |
| EC-VA-H264-8b-30-720-M | H.264 | up to High | up to 720i/p | 4:2:0/4:2:2 | 8 bits | up to 30fps | AAC | SoM-X-A200T |
| EC-VA-H264-8b-60-720-M | H.264 | up to High | up to 720i/p | 4:2:0/4:2:2 | 8 bits | up to 60fps | AAC | SoM-X-A200T |
| EC-VA-H264-8b-30-1080-M | H.264 | up to High | up to 1080i/p | 4:2:0/4:2:2 | 8 bits | up to 30fps | AAC | SoM-X-A200T |
| EC-VA-H264-10b-30-1080-M | H.264 | up to High | up to 1080i/p | 4:2:0/4:2:2 | up to 10 bits | up to 30fps | AAC | SoM-X-A200T |
| EC-VA-H264-8b-60-1080-M | H.264 | up to High | up to 1080i/p | 4:2:0/4:2:2 | 8 bits | up to 60fps | AAC | SoM-X-A200T |
| EC-VA-H264-10b-60-1080-M | H.264 | up to High | up to 1080i/p | 4:2:0/4:2:2 | up to 10 bits | up to 60fps | AAC | SoM-X-A200T |

A.2 MPEG-2 HD (720@30, 720@60, 1080@30, and 1080@60) Encoder Modules

Table-A.2-1 provides a list of standard MPEG-2 HD video (without audio) Encoder Modules. Table-A.2-2 provides a list of standard MPEG-2 HD video&audio Encoder Modules. The product code, specifications, and the SoM hardware are detailed in the table.

Table-A.2-1: MPEG-2 HD Video Encoder Modules (video only without audio):

| Product # | Specifications | | | | | | | SoM |
|--------------------------|----------------|------------|---------------|-------------|-----------|-------------|-------|-------------|
| | Standard | Profile | Resolution | Chroma | Precision | Frame Rate | Audio | |
| EC-V-MPEG2-8b-30-720-M | H.264 | up to High | up to 720i/p | 4:2:0/4:2:2 | 8 bits | up to 30fps | no | SoM-X-A200T |
| EC-V- MPEG2-8b-60-720-M | H.264 | up to High | up to 720i/p | 4:2:0/4:2:2 | 8 bits | up to 60fps | no | SoM-X-A200T |
| EC-V- MPEG2-8b-30-1080-M | H.264 | up to High | up to 1080i/p | 4:2:0/4:2:2 | 8 bits | up to 30fps | no | SoM-X-A200T |
| EC-V- MPEG2-8b-60-1080-M | H.264 | up to High | up to 1080i/p | 4:2:0/4:2:2 | 8 bits | up to 60fps | no | SoM-X-A200T |

Table-A.2-2: MPEG-2 HD Video/Audio Encoder Modules (both video and audio):

| Product # | Specifications | | | | | | | SoM |
|---------------------------|----------------|------------|---------------|-------------|-----------|-------------|-----------|-------------|
| | Standard | Profile | Resolution | Chroma | Precision | Frame Rate | Audio | |
| EC-VA- MPEG2-8b-30-720-M | H.264 | up to High | up to 720i/p | 4:2:0/4:2:2 | 8 bits | up to 30fps | MPEG2-L2? | SoM-X-A200T |
| EC-VA- MPEG2-8b-60-720-M | H.264 | up to High | up to 720i/p | 4:2:0/4:2:2 | 8 bits | up to 60fps | MPEG2-L2? | SoM-X-A200T |
| EC-VA- MPEG2-8b-30-1080-M | H.264 | up to High | up to 1080i/p | 4:2:0/4:2:2 | 8 bits | up to 30fps | MPEG2-L2? | SoM-X-A200T |
| EC-VA- MPEG2-8b-60-1080-M | H.264 | up to High | up to 1080i/p | 4:2:0/4:2:2 | 8 bits | up to 60fps | MPEG2-L2? | SoM-X-A200T |

A.3 H.264 HD (720@30, 720@60, 1080@30, and 1080@60) Decoder Modules

Table-A.3-1 provides a list of standard H.264 HD video (without audio) Decoder Modules. Table-A.3-2 provides a list of standard H.264 HD video&audio Decoder Modules. The product code, specifications, and the SoM hardware are detailed in the table.

Table-A.3-1: H.264 HD Video Decoder Modules (video only without audio):

| Product # | Specifications | | | | | | | SoM |
|-------------------------|----------------|------------|---------------|-------------|---------------|-------------|-------|-------------|
| | Standard | Profile | Resolution | Chroma | Precision | Frame Rate | Audio | |
| DC-V-H264-8b-30-720-M | H.264 | up to High | up to 720i/p | 4:2:0/4:2:2 | 8 bits | up to 30fps | no | SoM-X-A200T |
| DC-V-H264-8b-60-720-M | H.264 | up to High | up to 720i/p | 4:2:0/4:2:2 | 8 bits | up to 60fps | no | SoM-X-A200T |
| DC-V-H264-8b-30-1080-M | H.264 | up to High | up to 1080i/p | 4:2:0/4:2:2 | 8 bits | up to 30fps | no | SoM-X-A200T |
| DC-V-H264-10b-30-1080-M | H.264 | up to High | up to 1080i/p | 4:2:0/4:2:2 | up to 10 bits | up to 30fps | no | SoM-X-A200T |
| DC-V-H264-8b-60-1080-M | H.264 | up to High | up to 1080i/p | 4:2:0/4:2:2 | 8 bits | up to 60fps | no | SoM-X-A200T |
| DC-V-H264-10b-60-1080-M | H.264 | up to High | up to 1080i/p | 4:2:0/4:2:2 | up to 10 bits | up to 60fps | no | SoM-X-A200T |

Table-A.3-2: H.264 HD Video/Audio Decoder Modules (both video and audio):

| Product # | Specifications | | | | | | | SoM |
|--------------------------|----------------|------------|---------------|-------------|---------------|-------------|-------|-------------|
| | Standard | Profile | Resolution | Chroma | Precision | Frame Rate | Audio | |
| DC-VA-H264-8b-30-720-M | H.264 | up to High | up to 720i/p | 4:2:0/4:2:2 | 8 bits | up to 30fps | AAC | SoM-X-A200T |
| DC-VA-H264-8b-60-720-M | H.264 | up to High | up to 720i/p | 4:2:0/4:2:2 | 8 bits | up to 60fps | AAC | SoM-X-A200T |
| DC-VA-H264-8b-30-1080-M | H.264 | up to High | up to 1080i/p | 4:2:0/4:2:2 | 8 bits | up to 30fps | AAC | SoM-X-A200T |
| DC-VA-H264-10b-30-1080-M | H.264 | up to High | up to 1080i/p | 4:2:0/4:2:2 | up to 10 bits | up to 30fps | AAC | SoM-X-A200T |
| DC-VA-H264-8b-60-1080-M | H.264 | up to High | up to 1080i/p | 4:2:0/4:2:2 | 8 bits | up to 60fps | AAC | SoM-X-A200T |
| DC-VA-H264-10b-60-1080-M | H.264 | up to High | up to 1080i/p | 4:2:0/4:2:2 | up to 10 bits | up to 60fps | AAC | SoM-X-A200T |

A.4 MPEG-2 HD (720@30, 720@60,1080@30, and 1080@60) Decoder Modules

Table-A.4-1 provides a list of standard MPEG-2 HD video (without audio) Decoder Modules. Table-A.4-2 provides a list of standard MPEG-2 HD video&audio Decoder Modules. The product code, specifications, and the SoM hardware are detailed in the table.

Table-A.4-1: MPEG-2 HD Video Decoder Modules (video only without audio):

| Product # | Specifications | | | | | | | SoM |
|--------------------------|----------------|------------|---------------|-------------|-----------|-------------|-------|-------------|
| | Standard | Profile | Resolution | Chroma | Precision | Frame Rate | Audio | |
| DC-V-MPEG2-8b-30-720-M | H.264 | up to High | up to 720i/p | 4:2:0/4:2:2 | 8 bits | up to 30fps | no | SoM-X-A200T |
| DC-V- MPEG2-8b-60-720-M | H.264 | up to High | up to 720i/p | 4:2:0/4:2:2 | 8 bits | up to 60fps | no | SoM-X-A200T |
| DC-V- MPEG2-8b-30-1080-M | H.264 | up to High | up to 1080i/p | 4:2:0/4:2:2 | 8 bits | up to 30fps | no | SoM-X-A200T |
| DC-V- MPEG2-8b-60-1080-M | H.264 | up to High | up to 1080i/p | 4:2:0/4:2:2 | 8 bits | up to 60fps | no | SoM-X-A200T |

Table-A.4-2: MPEG-2 HD Video/Audio Decoder Modules (both video and audio):

| Product # | Specifications | | | | | | | SoM |
|---------------------------|----------------|------------|---------------|-------------|-----------|-------------|--------------|-------------|
| | Standard | Profile | Resolution | Chroma | Precision | Frame Rate | Audio | |
| DC-VA- MPEG2-8b-30-720-M | H.264 | up to High | up to 720i/p | 4:2:0/4:2:2 | 8 bits | up to 30fps | MPEG2-L2AAC? | SoM-X-A200T |
| DC-VA- MPEG2-8b-60-720-M | H.264 | up to High | up to 720i/p | 4:2:0/4:2:2 | 8 bits | up to 60fps | MPEG2-L2AAC? | SoM-X-A200T |
| DC-VA- MPEG2-8b-30-1080-M | H.264 | up to High | up to 1080i/p | 4:2:0/4:2:2 | 8 bits | up to 30fps | MPEG2-L2AAC? | SoM-X-A200T |
| DC-VA- MPEG2-8b-60-1080-M | H.264 | up to High | up to 1080i/p | 4:2:0/4:2:2 | 8 bits | up to 60fps | MPEG2-L2AAC? | SoM-X-A200T |

A.5 H.264 4k@30 Encoder Modules

Table-A.5-1 provides a list of standard H.264 4k@30 video (without audio) Encoder Modules. Table-A.5-2 provides a list of standard H.264 4k@30 video&audio Encoder Modules. The product code, specifications, and the SoM hardware are detailed in the table.

Table-A.5-1: H.264 4k@30 Video Encoder Modules (video only without audio):

| Product # | Specifications | | | | | | | SoM |
|-----------------------|----------------|------------|------------|-------------|---------------|------------|-------|------------------|
| | Standard | Profile | Resolution | Chroma | Precision | Frame Rate | Audio | |
| EC-V-H264-8b-30-4k-M | H.264 | up to High | 4k | 4:2:0/4:2:2 | 8 bits | 30fps | no | SoM-X-Z7035/7045 |
| EC-V-H264-10b-30-4k-M | H.264 | up to High | 4k | 4:2:0/4:2:2 | up to 10 bits | 30fps | no | SoM-X-Z7035/7045 |

Table-A.5-2: H.264 4k@30 Video/Audio Encoder Modules (both video and audio):

| Product # | Specifications | | | | | | | SoM |
|------------------------|----------------|------------|------------|-------------|---------------|------------|-------|------------------|
| | Standard | Profile | Resolution | Chroma | Precision | Frame Rate | Audio | |
| EC-VA-H264-8b-30-4k-M | H.264 | up to High | 4k | 4:2:0/4:2:2 | 8 bits | 30fps | AAC | SoM-X-Z7035/7045 |
| EC-VA-H264-10b-30-4k-M | H.264 | up to High | 4k | 4:2:0/4:2:2 | up to 10 bits | 30fps | AAC | SoM-X-Z7035/7045 |

A.6 H.264 4k@30 Decoder Modules

Table-A.6-1 provides a list of standard H.264 4k@30 video (without audio) Decoder Modules. Table-A.6-2 provides a list of standard H.264 4k@30 video&audio Decoder Modules. The product code, specifications, and the SoM hardware are detailed in the table.

Table-A.6-1: H.264 4k@30 Video Decoder Modules (video only without audio):

| Product # | Specifications | | | | | | | SoM |
|-----------------------|----------------|------------|------------|-------------|--------------|------------|-------|------------------|
| | Standard | Profile | Resolution | Chroma | Precision | Frame Rate | Audio | |
| DC-V-H264-8b-30-4k-M | H.264 | up to High | 4k | 4:2:0/4:2:2 | 8 bits | 30fps | no | SoM-X-Z7035/7045 |
| DC-V-H264-10b-30-4k-M | H.264 | up to High | 4k | 4:2:0/4:2:2 | up to 10bits | 30fps | no | SoM-X-Z7035/7045 |

Table-A.6-2: H.264 4k@30 Video/Audio Decoder Modules (both video and audio):

| Product # | Specifications | | | | | | | SoM |
|------------------------|----------------|------------|------------|-------------|---------------|------------|-------|------------------|
| | Standard | Profile | Resolution | Chroma | Precision | Frame Rate | Audio | |
| DC-VA-H264-8b-30-4k-M | H.264 | up to High | 4k | 4:2:0/4:2:2 | 8 bits | 30fps | AAC | SoM-X-Z7035/7045 |
| DC-VA-H264-10b-30-4k-M | H.264 | up to High | 4k | 4:2:0/4:2:2 | up to 10 bits | 30fps | AAC | SoM-X-Z7035/7045 |

A.7 H.264 4k@60 Encoder Modules

Table-A.7-1 provides a list of standard H.264 4k@60 video (without audio) Encoder Modules. Table-A.7-2 provides a list of standard H.264 4k@60 video&audio Encoder Modules. The product code, specifications, and the SoM hardware are detailed in the table.

Table-A.7-1: H.264 4k@60 Video Encoder Modules (video only without audio):

| Product # | Specifications | | | | | | | SoM |
|-----------------------|----------------|------------|------------|-------------|---------------|------------|-------|-------------|
| | Standard | Profile | Resolution | Chroma | Precision | Frame Rate | Audio | |
| EC-V-H264-8b-60-4k-M | H.264 | up to High | 4k | 4:2:0/4:2:2 | 8 bits | 60fps | no | SoM-I-SX660 |
| EC-V-H264-10b-60-4k-M | H.264 | up to High | 4k | 4:2:0/4:2:2 | up to 10 bits | 60fps | no | SoM-I-SX660 |

Table-A.7-2: H.264 4k@60 Video/Audio Encoder Modules (both video and audio):

| Product # | Specifications | | | | | | | SoM |
|------------------------|----------------|------------|------------|-------------|---------------|------------|-------|-------------|
| | Standard | Profile | Resolution | Chroma | Precision | Frame Rate | Audio | |
| EC-VA-H264-8b-60-4k-M | H.264 | up to High | 4k | 4:2:0/4:2:2 | 8 bits | 60fps | AAC | SoM-I-SX660 |
| EC-VA-H264-10b-60-4k-M | H.264 | up to High | 4k | 4:2:0/4:2:2 | up to 10 bits | 60fps | AAC | SoM-I-SX660 |

A.8 H.264 4k@60 Decoder Modules

Table-A.8-1 provides a list of standard H.264 4k@60 video (without audio) Decoder Modules. Table-A.8-2 provides a list of standard H.264 4k@60 video&audio Decoder Modules. The product code, specifications, and the SoM hardware are detailed in the table.

Table-A.8-1: H.264 4k@60 Video Decoder Modules (video only without audio):

| Product # | Specifications | | | | | | | SoM |
|-----------------------|----------------|------------|------------|-------------|---------------|------------|-------|-------------|
| | Standard | Profile | Resolution | Chroma | Precision | Frame Rate | Audio | |
| DC-V-H264-8b-60-4k-M | H.264 | up to High | 4k | 4:2:0/4:2:2 | 8 bits | 60fps | no | SoM-I-SX660 |
| DC-V-H264-10b-60-4k-M | H.264 | up to High | 4k | 4:2:0/4:2:2 | up to 10 bits | 60fps | no | SoM-I-SX660 |

Table-A.8-2: H.264 4k@60 Video/Audio Decoder Modules (both video and audio):

| Product # | Specifications | | | | | | | SoM |
|------------------------|----------------|------------|------------|-------------|---------------|------------|-------|-------------|
| | Standard | Profile | Resolution | Chroma | Precision | Frame Rate | Audio | |
| DC-VA-H264-8b-60-4k-M | H.264 | up to High | 4k | 4:2:0/4:2:2 | 8 bits | 60fps | AAC | SoM-I-SX660 |
| DC-VA-H264-10b-60-4k-M | H.264 | up to High | 4k | 4:2:0/4:2:2 | up to 10 bits | 60fps | AAC | SoM-I-SX660 |

A.9 H.265 HD (720@30, 720@60, 1080@30, and 1080@60) Encoder Modules

Table-A.9-1 provides a list of standard H.265 HD video (without audio) Encoder Modules. Table-A.9-2 provides a list of standard H.265 HD video&audio Encoder Modules. The product code, specifications, and the SoM hardware are detailed in the table.

Table-A.9-1: H.265 HD Video Encoder Modules (video only without audio):

| Product # | Specifications | | | | | | | SoM |
|-------------------------|----------------|---------|---------------|-------------|-----------|-------------|-------|-------------|
| | Standard | Profile | Resolution | Chroma | Precision | Frame Rate | Audio | |
| EC-V-H265-8b-30-720-M | H.265/HEVC | Main 8 | up to 720i/p | 4:2:0/4:2:2 | 8 bits | up to 30fps | no | SoM-X-Z7045 |
| EC-V-H265-8b-60-720-M | H.265/HEVC | Main 8 | up to 720i/p | 4:2:0/4:2:2 | 8 bits | up to 60fps | no | SoM-X-Z7045 |
| EC-V-H265-8b-30-1080-M | H.265/HEVC | Main 8 | up to 1080i/p | 4:2:0/4:2:2 | 8 bits | up to 30fps | no | SoM-X-Z7045 |
| EC-V-H265-10b-30-1080-M | H.265/HEVC | Main 10 | up to 1080i/p | 4:2:0/4:2:2 | 10 bits | up to 30fps | no | SoM-X-Z7045 |
| EC-V-H265-8b-60-1080-M | H.265/HEVC | Main 8 | up to 1080i/p | 4:2:0/4:2:2 | 8 bits | up to 60fps | no | SoM-X-Z7045 |
| EC-V-H265-10b-60-1080-M | H.265/HEVC | Main 10 | up to 1080i/p | 4:2:0/4:2:2 | 10 bits | up to 60fps | no | SoM-X-Z7045 |

Table-A.9-2: H.265 HD Video/Audio Encoder Modules (both video and audio):

| Product # | Specifications | | | | | | | SoM |
|--------------------------|----------------|---------|---------------|-------------|-----------|-------------|-------|-------------|
| | Standard | Profile | Resolution | Chroma | Precision | Frame Rate | Audio | |
| EC-VA-H265-8b-30-720-M | H.265/HEVC | Main 8 | up to 720i/p | 4:2:0/4:2:2 | 8 bits | up to 30fps | AAC | SoM-X-Z7045 |
| EC-VA-H265-8b-60-720-M | H.265/HEVC | Main 8 | up to 720i/p | 4:2:0/4:2:2 | 8 bits | up to 60fps | AAC | SoM-X-Z7045 |
| EC-VA-H265-8b-30-1080-M | H.265/HEVC | Main 8 | up to 1080i/p | 4:2:0/4:2:2 | 8 bits | up to 30fps | AAC | SoM-X-Z7045 |
| EC-VA-H265-10b-30-1080-M | H.265/HEVC | Main 10 | up to 1080i/p | 4:2:0/4:2:2 | 10 bits | up to 30fps | AAC | SoM-X-Z7045 |
| EC-VA-H265-8b-60-1080-M | H.265/HEVC | Main 8 | up to 1080i/p | 4:2:0/4:2:2 | 8 bits | up to 60fps | AAC | SoM-X-Z7045 |
| EC-VA-H265-10b-60-1080-M | H.265/HEVC | Main 10 | up to 1080i/p | 4:2:0/4:2:2 | 10 bits | up to 60fps | AAC | SoM-X-Z7045 |

A.10 H.265 HD (720@30, 720@60,1080@30, and 1080@60) Decoder Modules

Table-A.10-1 provides a list of standard H.265 HD video (without audio) Decoder Modules. Table-A.10-2 provides a list of standard H.265 HD video&audio Decoder Modules. The product code, specifications, and the SoM hardware are detailed in the table.

Table-A.10-1: H.265 HD Video Decoder Modules (video only without audio):

| Product # | Specifications | | | | | | | SoM |
|-------------------------|----------------|---------|---------------|-------------|-----------|-------------|-------|-------------|
| | Standard | Profile | Resolution | Chroma | Precision | Frame Rate | Audio | |
| DC-V-H265-8b-30-720-M | H.265/HEVC | Main 8 | up to 720i/p | 4:2:0/4:2:2 | 8 bits | up to 30fps | no | SoM-X-Z7045 |
| DC-V-H265-8b-60-720-M | H.265/HEVC | Main 8 | up to 720i/p | 4:2:0/4:2:2 | 8 bits | up to 60fps | no | SoM-X-Z7045 |
| DC-V-H265-8b-30-1080-M | H.265/HEVC | Main 8 | up to 1080i/p | 4:2:0/4:2:2 | 8 bits | up to 30fps | no | SoM-X-Z7045 |
| DC-V-H265-10b-30-1080-M | H.265/HEVC | Main 10 | up to 1080i/p | 4:2:0/4:2:2 | 10 bits | up to 30fps | no | SoM-X-Z7045 |
| DC-V-H265-8b-60-1080-M | H.265/HEVC | Main 8 | up to 1080i/p | 4:2:0/4:2:2 | 8 bits | up to 60fps | no | SoM-X-Z7045 |
| DC-V-H265-10b-60-1080-M | H.265/HEVC | Main 10 | up to 1080i/p | 4:2:0/4:2:2 | 10 bits | up to 60fps | no | SoM-X-Z7045 |

Table-A.10-2: H.265 HD Video/Audio Decoder Modules (both video and audio):

| Product # | Specifications | | | | | | | SoM |
|--------------------------|----------------|---------|---------------|-------------|-----------|-------------|-------|-------------|
| | Standard | Profile | Resolution | Chroma | Precision | Frame Rate | Audio | |
| DC-VA-H265-8b-30-720-M | H.265/HEVC | Main 8 | up to 720i/p | 4:2:0/4:2:2 | 8 bits | up to 30fps | AAC | SoM-X-Z7045 |
| DC-VA-H265-8b-60-720-M | H.265/HEVC | Main 8 | up to 720i/p | 4:2:0/4:2:2 | 8 bits | up to 60fps | AAC | SoM-X-Z7045 |
| DC-VA-H265-8b-30-1080-M | H.265/HEVC | Main 8 | up to 1080i/p | 4:2:0/4:2:2 | 8 bits | up to 30fps | AAC | SoM-X-Z7045 |
| DC-VA-H265-10b-30-1080-M | H.265/HEVC | Main 10 | up to 1080i/p | 4:2:0/4:2:2 | 10 bits | up to 30fps | AAC | SoM-X-Z7045 |
| DC-VA-H265-8b-60-1080-M | H.265/HEVC | Main 8 | up to 1080i/p | 4:2:0/4:2:2 | 8 bits | up to 60fps | AAC | SoM-X-Z7045 |
| DC-VA-H265-10b-60-1080-M | H.265/HEVC | Main 10 | up to 1080i/p | 4:2:0/4:2:2 | 10 bits | up to 60fps | AAC | SoM-X-Z7045 |

A.11 H.265 4k@30 Encoder Modules

Table-A.11-1 provides a list of standard H.265 4k@30 video (without audio) Encoder Modules. Table-A.11-2 provides a list of standard H.265 4k@30 video&audio Encoder Modules. The product code, specifications, and the SoM hardware are detailed in the table.

Table-A.11-1: H.265 4k@30 Video Encoder Modules (video only without audio):

| Product # | Specifications | | | | | | | SoM |
|-----------------------|----------------|---------|------------|-------------|---------------|------------|-------|-------------|
| | Standard | Profile | Resolution | Chroma | Precision | Frame Rate | Audio | |
| EC-V-H265-8b-30-4k-M | H.265 | Main 8 | 4k | 4:2:0/4:2:2 | 8 bits | 30fps | no | SoM-X-Z7045 |
| EC-V-H265-10b-30-4k-M | H.265 | Main 10 | 4k | 4:2:0/4:2:2 | up to 10 bits | 30fps | no | SoM-X-Z7045 |

Table-A.11-2: H.265 4k@30 Video/Audio Encoder Modules (both video and audio):

| Product # | Specifications | | | | | | | Hardware |
|------------------------|----------------|---------|------------|-------------|---------------|------------|-------|-------------|
| | Standard | Profile | Resolution | Chroma | Precision | Frame Rate | Audio | |
| EC-VA-H265-8b-30-4k-M | H.265 | Main 8 | 4k | 4:2:0/4:2:2 | 8 bits | 30fps | AAC | SoM-X-Z7045 |
| EC-VA-H265-10b-30-4k-M | H.265 | Main 10 | 4k | 4:2:0/4:2:2 | up to 10 bits | 30fps | AAC | SoM-X-Z7045 |

A.12 H.265 4k@30 Decoder Modules

Table-A.12-1 provides a list of standard H.265 4k@30 video (without audio) Decoder Modules. Table-A.12-2 provides a list of standard H.265 4k@30 video&audio Decoder Modules. The product code, specifications, and the SoM hardware are detailed in the table.

Table-A.12-1: H.265 4k@30 Video Decoder Modules (video only without audio):

| Product # | Specifications | | | | | | | SoM |
|-----------------------|----------------|---------|------------|-------------|---------------|------------|-------|-------------|
| | Standard | Profile | Resolution | Chroma | Precision | Frame Rate | Audio | |
| DC-V-H265-8b-30-4k-M | H.265 | Main 8 | 4k | 4:2:0/4:2:2 | 8 bits | 30fps | no | SoM-X-Z7045 |
| DC-V-H265-10b-30-4k-M | H.265 | Main 10 | 4k | 4:2:0/4:2:2 | up to 10 bits | 30fps | no | SoM-X-Z7045 |

Table-A.12-2: H.265 4k@30 Video/Audio Decoder Modules (both video and audio):

| Product # | Specifications | | | | | | | SoM |
|------------------------|----------------|---------|------------|-------------|---------------|------------|-------|-------------|
| | Standard | Profile | Resolution | Chroma | Precision | Frame Rate | Audio | |
| DC-VA-H265-8b-30-4k-M | H.265 | Main 8 | 4k | 4:2:0/4:2:2 | 8 bits | 30fps | AAC | SoM-X-Z7045 |
| DC-VA-H265-10b-30-4k-M | H.265 | Main 10 | 4k | 4:2:0/4:2:2 | up to 10 bits | 30fps | AAC | SoM-X-Z7045 |

A.13 H.265 4k@60 Encoder Modules

To be added

A.14 H.265 4k@60 Decoder Modules

To be added

A.17 H.264-to-MPEG2 Transcoder Modules

Table-A.17-1 provides a list of standard H.264-to-MPEG2 Video Transcoder Modules. Table-A.17-2 provides a list of standard H.264-to-MPEG2 Video and Audio Transcoder Modules. The product code, specifications, and the SoM hardware are detailed in the table.

Table-A.17-1: H.264-to-MPEG2 Video Transcoder Modules (video only without audio):

| Product # | Specifications | | | | | | | SoM |
|-----------------------------------|----------------|---------|---------------|-------------|-----------|-------------|-------|-------------|
| | Standard | Profile | Resolution | Chroma | Precision | Frame Rate | Audio | |
| TC-V-H.264-to-MPEG2-8b-30-720-M | H.264 to MPEG2 | High | up to 720i/p | up to 4:2:2 | 8 bits | up to 30fps | no | SoM-X-A200T |
| TC-V- H.264-to-MPEG2-8b-60-720-M | H.264 to MPEG2 | High | up to 720i/p | up to 4:2:2 | 8 bits | up to 60fps | no | SoM-X-A200T |
| TC-V- H.264-to-MPEG2-8b-30-1080-M | H.264 to MPEG2 | High | up to 1080i/p | up to 4:2:2 | 8 bits | up to 30fps | no | SoM-X-A200T |
| TC-V- H.264-to-MPEG2-8b-60-1080-M | H.264 to MPEG2 | High | up to 1080i/p | up to 4:2:2 | 8 bits | up to 60fps | no | SoM-X-A200T |

Table-A.17-2: H.264-to-MPEG2 Video&Audio Transcoder Modules (both video and audio):

| Product # | Specifications | | | | | | | SoM |
|-------------------------------------|----------------|---------|---------------|-------------|-----------|-------------|------------------|-------------|
| | Standard | Profile | Resolution | Chroma | Precision | Frame Rate | Audio | |
| TC-VA- H.264-to -MPEG2-8b-30-720-M | H.264 to MPEG2 | High | up to 720i/p | up to 4:2:2 | 8 bits | up to 30fps | AAC to MPEG2-L2? | SoM-X-A200T |
| TC-VA- H.264-to -MPEG2-8b-60-720-M | H.264 to MPEG2 | High | up to 720i/p | up to 4:2:2 | 8 bits | up to 60fps | AAC to MPEG2-L2? | SoM-X-A200T |
| TC-VA- H.264-to -MPEG2-8b-30-1080-M | H.264 to MPEG2 | High | up to 1080i/p | up to 4:2:2 | 8 bits | up to 30fps | AAC to MPEG2-L2? | SoM-X-A200T |
| TC-VA- H.264-to -MPEG2-8b-60-1080-M | H.264 to MPEG2 | High | up to 1080i/p | up to 4:2:2 | 8 bits | up to 60fps | AAC to MPEG2-L2? | SoM-X-A200T |

A.18 MPEG2-to-H.264 Transcoder Modules

Table-A.18-1 provides a list of standard MPEG2-to-H.264 Video Transcoder Modules. Table-A.18-2 provides a list of standard MPEG-2-to-H.264 Video and Audio Transcoder Modules. The product code, specifications, and the SoM hardware are detailed in the table.

Table-A.18-1: MPEG2-to-H264 Video Transcoder Modules (video only without audio):

| Product # | Specifications | | | | | | | SoM |
|----------------------------------|----------------|---------|---------------|-------------|-----------|-------------|-------|-------------|
| | Standard | Profile | Resolution | Chroma | Precision | Frame Rate | Audio | |
| TC-V-MPEG2-to-H264-8b-30-720-M | MPEG2 to H.264 | High | up to 720i/p | up to 4:2:2 | 8 bits | up to 30fps | no | SoM-X-A200T |
| TC-V- MPEG2-to-H264-8b-60-720-M | MPEG2 to H.264 | High | up to 720i/p | up to 4:2:2 | 8 bits | up to 60fps | no | SoM-X-A200T |
| TC-V- MPEG2-to-H264-8b-30-1080-M | MPEG2 to H.264 | High | up to 1080i/p | up to 4:2:2 | 8 bits | up to 30fps | no | SoM-X-A200T |
| TC-V- MPEG2-to-H264-8b-60-1080-M | MPEG2 to H.264 | High | up to 1080i/p | up to 4:2:2 | 8 bits | up to 60fps | no | SoM-X-A200T |

Table-A.20-2: MPEG2-to-H264 Video&Audio Transcoder Modules (both video and audio):

| Product # | Specifications | | | | | | | SoM |
|----------------------------------|----------------|---------|---------------|-------------|-----------|-------------|-----------------|-------------|
| | Standard | Profile | Resolution | Chroma | Precision | Frame Rate | Audio | |
| TC-V-MPEG2-to-H264-8b-30-720-M | MPEG2 to H.264 | High | up to 720i/p | up to 4:2:2 | 8 bits | up to 30fps | MPEG2-L2 to AAC | SoM-X-A200T |
| TC-V- MPEG2-to-H264-8b-60-720-M | MPEG2 to H.264 | High | up to 720i/p | up to 4:2:2 | 8 bits | up to 60fps | MPEG2-L2 to AAC | SoM-X-A200T |
| TC-V- MPEG2-to-H264-8b-30-1080-M | MPEG2 to H.264 | High | up to 1080i/p | up to 4:2:2 | 8 bits | up to 30fps | MPEG2-L2 to AAC | SoM-X-A200T |
| TC-V- MPEG2-to-H264-8b-60-1080-M | MPEG2 to H.264 | High | up to 1080i/p | up to 4:2:2 | 8 bits | up to 60fps | MPEG2-L2 to AAC | SoM-X-A200T |

A.21 H.264-to-H.265 Transcoder Modules

Table-A.21-1 provides a list of standard H.264-to-H.265 Video Transcoder Modules. Table-A.21-2 provides a list of standard H.264-to-H.265 Video and Audio Transcoder Modules. The product code, specifications, and the SoM hardware are detailed in the table.

Table-A21-1: H.264-to-H.265 Video Transcoder Modules (video only without audio):

| Product # | Specifications | | | | | | | SoM |
|------------------------------------|----------------|-----------------|---------------|-------------|-----------|-------------|-------|-------------|
| | Standard | Profile | Resolution | Chroma | Precision | Frame Rate | Audio | |
| TC-V-H.264-to-H.265-8b-30-720-M | H.264 to H.265 | High to Main 8 | up to 720i/p | up to 4:2:2 | 8 bits | up to 30fps | no | SoM-I-SX660 |
| TC-V-H.264-to-H.265-10b-30-720-M | H.264 to H.265 | High to Main 10 | up to 720i/p | up to 4:2:2 | 10 bits | up to 30fps | no | SoM-I-SX660 |
| TC-V- H.264-to-H.265-8b-60-720-M | H.264 to H.265 | High to Main 8 | up to 720i/p | up to 4:2:2 | 8 bits | up to 60fps | no | SoM-I-SX660 |
| TC-V- H.264-to-H.265-10b-60-720-M | H.264 to H.265 | High to Main 10 | up to 720i/p | up to 4:2:2 | 10 bits | up to 60fps | no | SoM-I-SX660 |
| TC-V- H.264-to-H.265-8b-30-1080-M | H.264 to H.265 | High to Main 8 | up to 1080i/p | up to 4:2:2 | 8 bits | up to 30fps | no | SoM-I-SX660 |
| TC-V- H.264-to-H.265-10b-30-1080-M | H.264 to H.265 | High to Main 10 | up to 1080i/p | up to 4:2:2 | 10 bits | up to 30fps | no | SoM-I-SX660 |
| TC-V- H.264-to-H.265-8b-60-1080-M | H.264 to H.265 | High to Main 8 | up to 1080i/p | up to 4:2:2 | 8 bits | up to 60fps | no | SoM-I-SX660 |
| TC-V- H.264-to-H.265-10b-60-1080-M | H.264 to H.265 | High to Main 10 | up to 1080i/p | up to 4:2:2 | 10 bits | up to 60fps | no | SoM-I-SX660 |

Table-A21-2: H.264-to-H.265 Video & Audio Transcoder Modules (both video and audio):

| Product # | Specifications | | | | | | | SoM |
|------------------------------------|----------------|-----------------|---------------|-------------|-----------|-------------|-------|-------------|
| | Standard | Profile | Resolution | Chroma | Precision | Frame Rate | Audio | |
| TC-V-H.264-to-H.265-8b-30-720-M | H.264 to H.265 | High to Main 8 | up to 720i/p | up to 4:2:2 | 8 bits | up to 30fps | AAC | SoM-I-SX660 |
| TC-V-H.264-to-H.265-10b-30-720-M | H.264 to H.265 | High to Main 10 | up to 720i/p | up to 4:2:2 | 10 bits | up to 30fps | AAC | SoM-I-SX660 |
| TC-V- H.264-to-H.265-8b-60-720-M | H.264 to H.265 | High to Main 8 | up to 720i/p | up to 4:2:2 | 8 bits | up to 60fps | AAC | SoM-I-SX660 |
| TC-V- H.264-to-H.265-10b-60-720-M | H.264 to H.265 | High to Main 10 | up to 720i/p | up to 4:2:2 | 10 bits | up to 60fps | AAC | SoM-I-SX660 |
| TC-V- H.264-to-H.265-8b-30-1080-M | H.264 to H.265 | High to Main 8 | up to 1080i/p | up to 4:2:2 | 8 bits | up to 30fps | AAC | SoM-I-SX660 |
| TC-V- H.264-to-H.265-10b-30-1080-M | H.264 to H.265 | High to Main 10 | up to 1080i/p | up to 4:2:2 | 10 bits | up to 30fps | ACC | SoM-I-SX660 |
| TC-V- H.264-to-H.265-8b-60-1080-M | H.264 to H.265 | High to Main 8 | up to 1080i/p | up to 4:2:2 | 8 bits | up to 60fps | AAC | SoM-I-SX660 |
| TC-V- H.264-to-H.265-10b-60-1080-M | H.264 to H.265 | High to Main 10 | up to 1080i/p | up to 4:2:2 | 10 bits | up to 60fps | AAC | SoM-I-SX660 |

A.22 H.265-to-H.264 Transcoder Modules

Table-A.22-1 provides a list of standard H.265-to-H.264 Video Transcoder Modules. Table-A.22-2 provides a list of standard H.265-to-H.264 Video and Audio Transcoder Modules. The product code, specifications, and the SoM hardware are detailed in the table.

Table-A.22-1: H.265-to-H.264 Video Transcoder Modules (video only without audio):

| Product # | Specifications | | | | | | | SoM |
|------------------------------------|----------------|-----------------|---------------|-------------|-----------|-------------|-------|--------------|
| | Standard | Profile | Resolution | Chroma | Precision | Frame Rate | Audio | |
| TC-V-H.265-to-H.264-8b-30-720-M | H.265 to H.264 | Main 8 to High | up to 720i/p | up to 4:2:2 | 8 bits | up to 30fps | no | SoM-I-SX660 |
| TC-V-H.265-to-H.264-10b-30-720-M | H.265 to H.264 | Main 10 to High | up to 720i/p | up to 4:2:2 | 10 bits | up to 30fps | no | SoM-I-SX660 |
| TC-V- H.265-to-H.264-8b-60-720-M | H.265 to H.264 | Main 8 to High | up to 720i/p | up to 4:2:2 | 8 bits | up to 60fps | no | SoM-I-A660SX |
| TC-V- H.265-to-H.264-10b-60-720-M | H.265 to H.264 | Main 10 to High | up to 720i/p | up to 4:2:2 | 10 bits | up to 60fps | no | SoM-I-SX660 |
| TC-V- H.265-to-H.264-8b-30-1080-M | H.265 to H.264 | Main 8 to High | up to 1080i/p | up to 4:2:2 | 8 bits | up to 30fps | no | SoM-I-SX660 |
| TC-V- H.265-to-H.264-10b-30-1080-M | H.265 to H.264 | Main 10 to High | up to 1080i/p | up to 4:2:2 | 10 bits | up to 30fps | no | SoM-I-SX660 |
| TC-V- H.265-to-H.264-8b-60-1080-M | H.265 to H.264 | Main 8 to High | up to 1080i/p | up to 4:2:2 | 8 bits | up to 60fps | no | SoM-I-SX660 |
| TC-V- H.265-to-H.264-10b-60-1080-M | H.265 to H.264 | Main 10 to High | up to 1080i/p | up to 4:2:2 | 10 bits | up to 60fps | no | SoM-I-SX660 |

Table-A.22-2: H.265-to-H.264 Video & Audio Transcoder Modules (both video and audio):

| Product # | Specifications | | | | | | | SoM |
|------------------------------------|----------------|-----------------|---------------|-------------|-----------|-------------|-------|-------------|
| | Standard | Profile | Resolution | Chroma | Precision | Frame Rate | Audio | |
| TC-V-H.265-to-H.264-8b-30-720-M | H.265 to H.264 | Main 8 to High | up to 720i/p | up to 4:2:2 | 8 bits | up to 30fps | AAC | SoM-I-SX660 |
| TC-V-H.265-to-H.264-10b-30-720-M | H.265 to H.264 | Main 10 to High | up to 720i/p | up to 4:2:2 | 10 bits | up to 30fps | AAC | SoM-I-SX660 |
| TC-V- H.265-to-H.264-8b-60-720-M | H.265 to H.264 | Main 8 to High | up to 720i/p | up to 4:2:2 | 8 bits | up to 60fps | AAC | SoM-I-SX660 |
| TC-V- H.265-to-H.264-10b-60-720-M | H.265 to H.264 | Main 10 to High | up to 720i/p | up to 4:2:2 | 10 bits | up to 60fps | AAC | SoM-I-SX660 |
| TC-V- H.265-to-H.264-8b-30-1080-M | H.265 to H.264 | Main 8 to High | up to 1080i/p | up to 4:2:2 | 8 bits | up to 30fps | AAC | SoM-I-SX660 |
| TC-V- H.265-to-H.264-10b-30-1080-M | H.265 to H.264 | Main 10 to High | up to 1080i/p | up to 4:2:2 | 10 bits | up to 30fps | AAC | SoM-I-SX660 |
| TC-V- H.265-to-H.264-8b-60-1080-M | H.265 to H.264 | Main 8 to High | up to 1080i/p | up to 4:2:2 | 8 bits | up to 60fps | AAC | SoM-I-SX660 |
| TC-V- H.265-to-H.264-10b-60-1080-M | H.265 to H.264 | Main 10 to High | up to 1080i/p | up to 4:2:2 | 10 bits | up to 60fps | AAC | SoM-I-SX660 |

A.23 Non-Standard Codec Modules

The previous section provides the information on SOC's factory standard MPEG codec modules. Customers can order modules based on customer specific requirements (non-standard modules). There is a Minimum Order Quantity (MOQ) required for customized configurations. Contact SOC sales sale@soctechnologies.com for information.

Appendix - B SoM-X-A200T Edge Connector Schematics

Legend

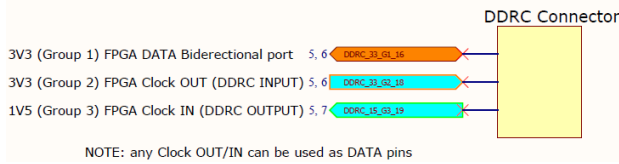

FPGA - DDRDC signals (97 @ 3V3, 32 @ 1V5)

- 34 x DDRDC Signals Group 1 @ 3V3
- 45 x DDRDC Signals Group 2 @ 3V3
- 32 x DDRDC Signals Group 3 @ 1V5
- 18 x DDRDC Signals Group 4 @ 3V3

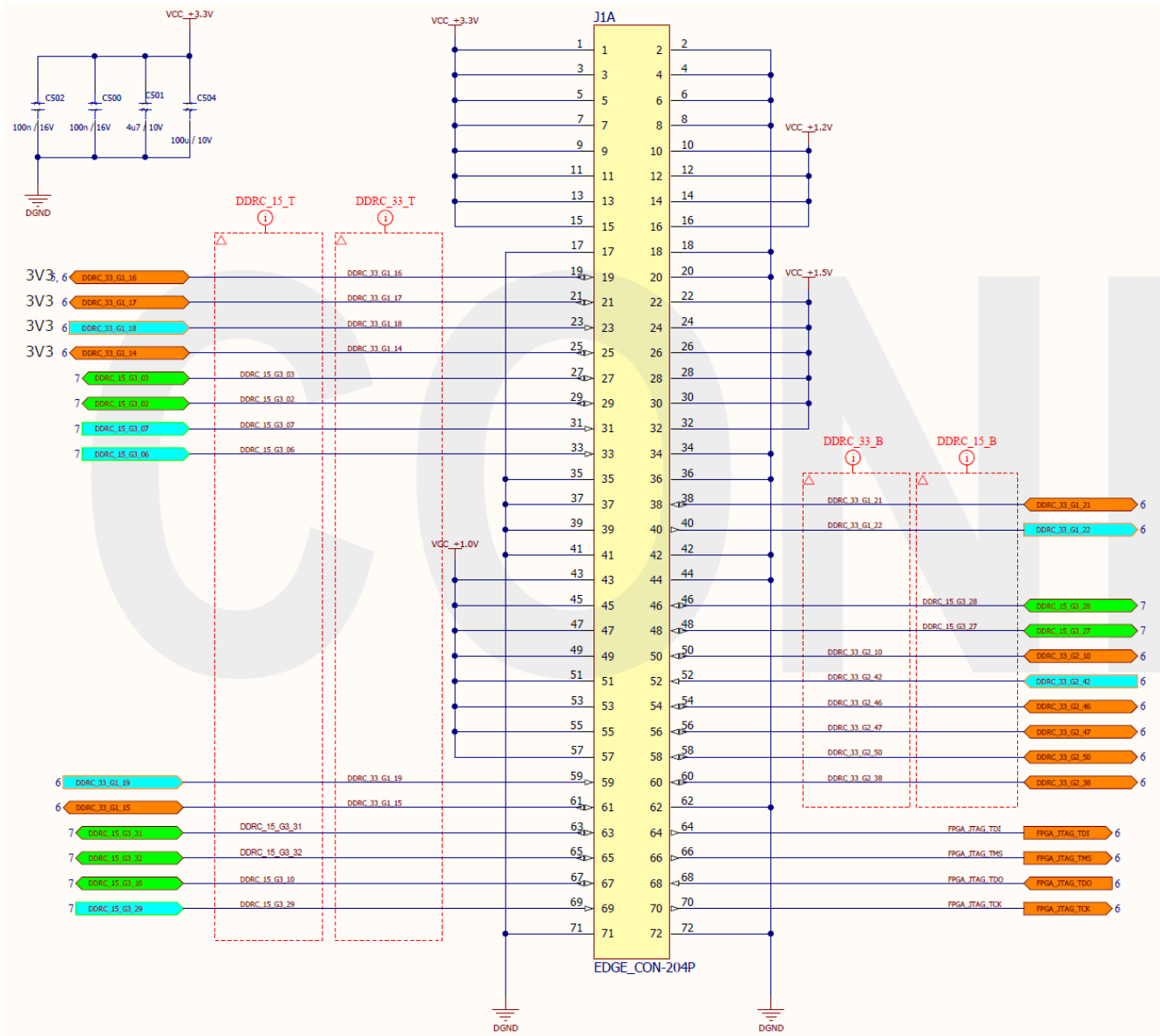

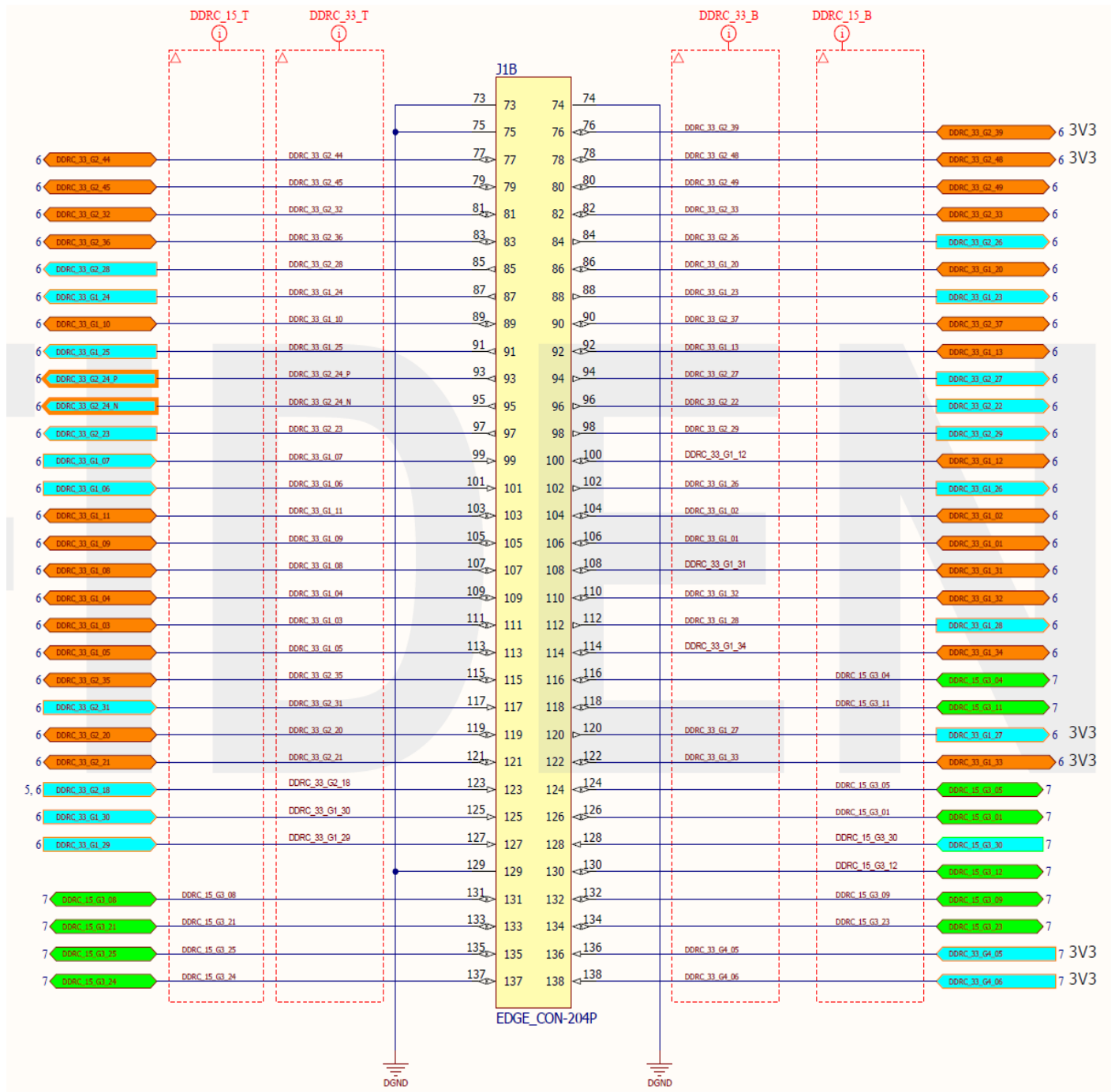

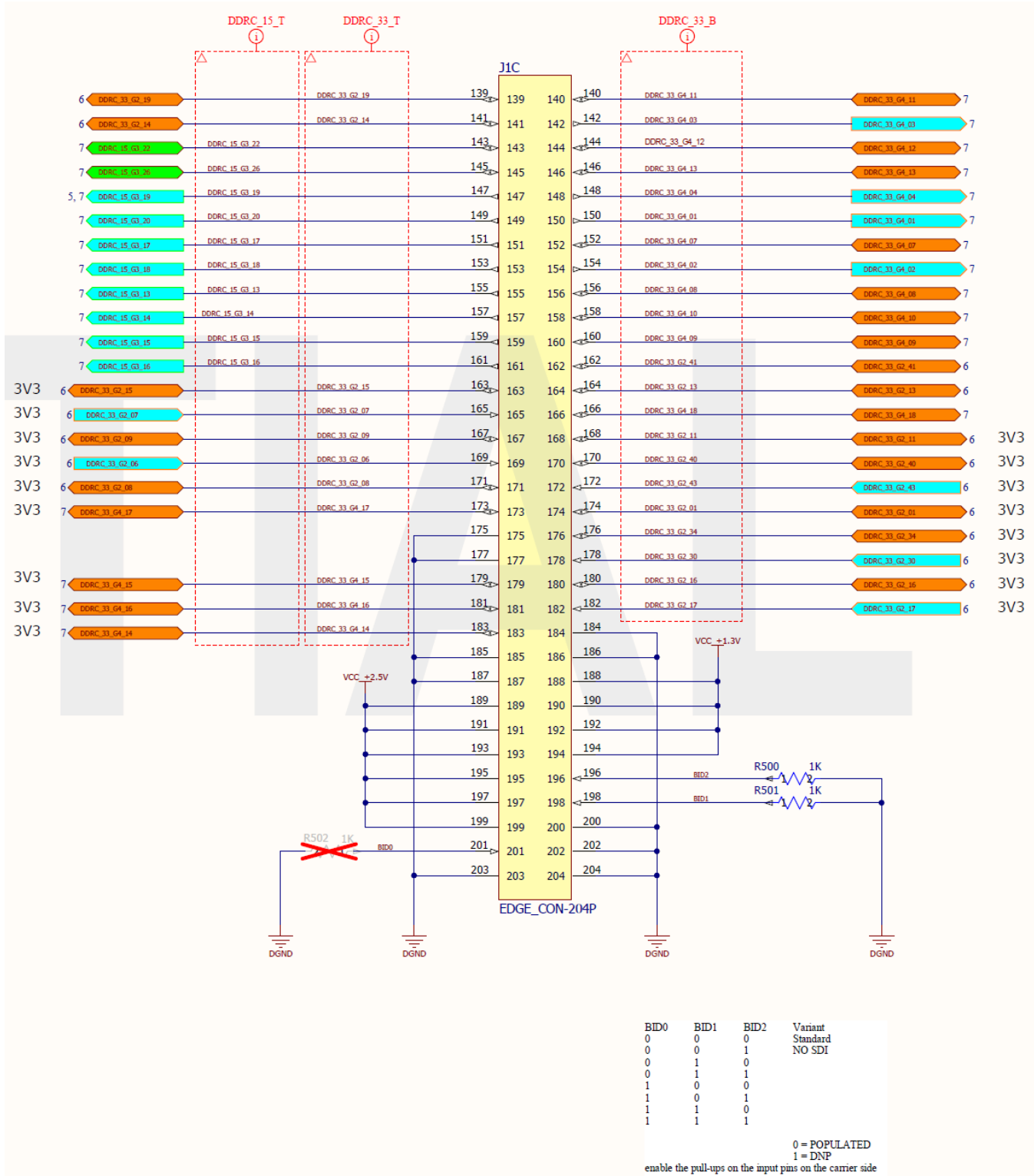

Appendix - C SoM-X-Z7045 Edge Connector Schematics

SODIMM-204P Edge Connector

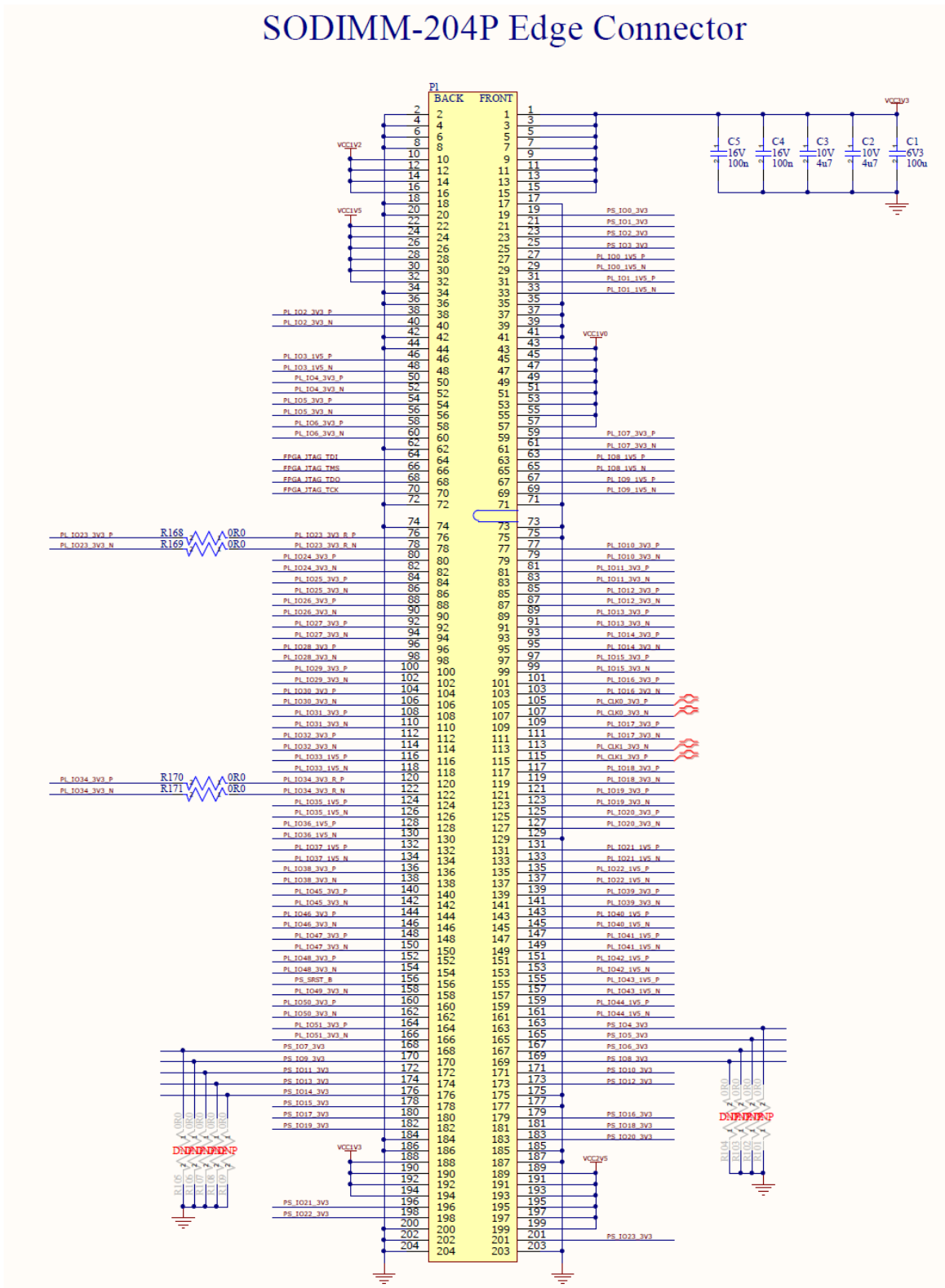

| | |
|---------------|---------------|
| FPGA_JTAG_TDI | FPGA_JTAG_TDI |
| FPGA_JTAG_TMS | FPGA_JTAG_TMS |
| FPGA_JTAG_TDO | FPGA_JTAG_TDO |
| FPGA_JTAG_TCK | FPGA_JTAG_TCK |

JTAG

To FPGA Bank 0
3V3 Signals

| | |
|-------------|-------------|
| PS_I00_3V3 | PS_I00_3V3 |
| PS_I01_3V3 | PS_I01_3V3 |
| PS_I02_3V3 | PS_I02_3V3 |
| PS_I03_3V3 | PS_I03_3V3 |
| PS_I04_3V3 | PS_I04_3V3 |
| PS_I05_3V3 | PS_I05_3V3 |
| PS_I06_3V3 | PS_I06_3V3 |
| PS_I07_3V3 | PS_I07_3V3 |
| PS_I08_3V3 | PS_I08_3V3 |
| PS_I09_3V3 | PS_I09_3V3 |
| PS_I010_3V3 | PS_I010_3V3 |
| PS_I011_3V3 | PS_I011_3V3 |
| PS_I012_3V3 | PS_I012_3V3 |
| PS_I013_3V3 | PS_I013_3V3 |
| PS_I014_3V3 | PS_I014_3V3 |
| PS_I015_3V3 | PS_I015_3V3 |
| PS_I016_3V3 | PS_I016_3V3 |
| PS_I017_3V3 | PS_I017_3V3 |
| PS_I018_3V3 | PS_I018_3V3 |
| PS_I019_3V3 | PS_I019_3V3 |
| PS_I020_3V3 | PS_I020_3V3 |
| PS_I021_3V3 | PS_I021_3V3 |
| PS_I022_3V3 | PS_I022_3V3 |
| PS_I023_3V3 | PS_I023_3V3 |

PS_3V3

To FPGA PS Banks 500, 501
3V3 Signals

| | |
|---------------|---------------|
| PL_I00_1V5_P | PL_I00_1V5_P |
| PL_I00_1V5_N | PL_I00_1V5_N |
| PL_I01_1V5_P | PL_I01_1V5_P |
| PL_I01_1V5_N | PL_I01_1V5_N |
| PL_I03_1V5_P | PL_I03_1V5_P |
| PL_I03_1V5_N | PL_I03_1V5_N |
| PL_I08_1V5_P | PL_I08_1V5_P |
| PL_I08_1V5_N | PL_I08_1V5_N |
| PL_I09_1V5_P | PL_I09_1V5_P |
| PL_I09_1V5_N | PL_I09_1V5_N |
| PL_I021_1V5_P | PL_I021_1V5_P |
| PL_I021_1V5_N | PL_I021_1V5_N |
| PL_I022_1V5_P | PL_I022_1V5_P |
| PL_I022_1V5_N | PL_I022_1V5_N |
| PL_I033_1V5_P | PL_I033_1V5_P |
| PL_I033_1V5_N | PL_I033_1V5_N |
| PL_I035_1V5_P | PL_I035_1V5_P |
| PL_I035_1V5_N | PL_I035_1V5_N |
| PL_I036_1V5_P | PL_I036_1V5_P |
| PL_I036_1V5_N | PL_I036_1V5_N |
| PL_I037_1V5_P | PL_I037_1V5_P |
| PL_I037_1V5_N | PL_I037_1V5_N |
| PL_I040_1V5_P | PL_I040_1V5_P |
| PL_I040_1V5_N | PL_I040_1V5_N |
| PL_I041_1V5_P | PL_I041_1V5_P |
| PL_I041_1V5_N | PL_I041_1V5_N |
| PL_I042_1V5_P | PL_I042_1V5_P |
| PL_I042_1V5_N | PL_I042_1V5_N |
| PL_I043_1V5_P | PL_I043_1V5_P |
| PL_I043_1V5_N | PL_I043_1V5_N |
| PL_I044_1V5_P | PL_I044_1V5_P |
| PL_I044_1V5_N | PL_I044_1V5_N |

PL_1V5

To FPGA PL Banks 9, 13
1V5 Signals

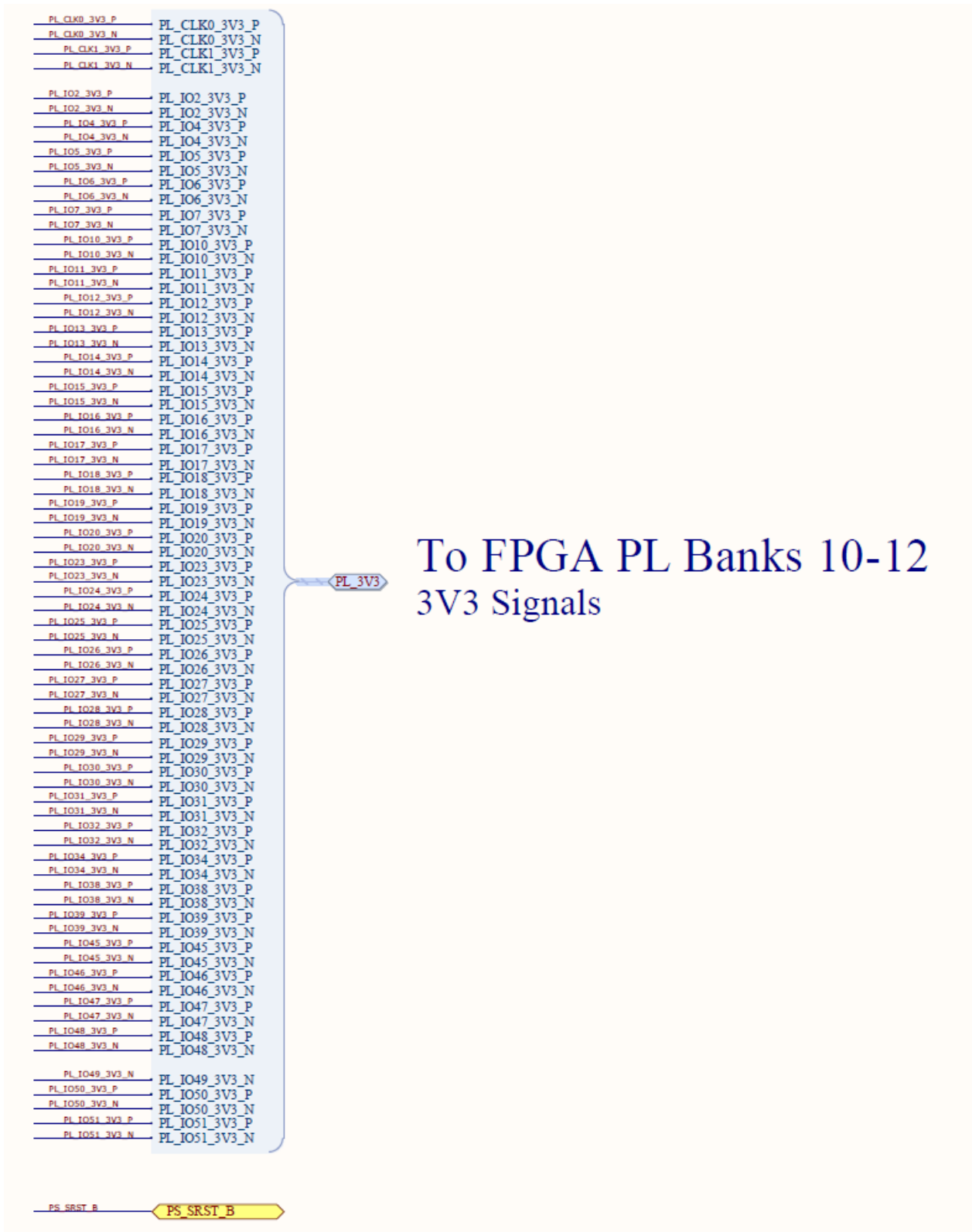

Appendix - D SoM-I-SX660 Edge Connector Schematics

SODIMM-204P Edge Connector

