

AC Series • Current Transformer Quick Reference Guide

Low Cost 50/60Hz Current Transformers

Applications

- Sensing Overload Current
- Ground fault detection
- Metering
- Analog to Digital Circuits

Features

- Excellent quality at extremely competitive price due to high volume production
- Manufactured in an ISO-9001 approved facility



Electrical Specifications @ 20°C ambient

AC Series • Standard Accuracy Current Transformers

Part No.	I _p Amps	Turns Ratio	Terminating Resistor		DCR (Ohms)	RCF @ 10%	Volts/Amp @ rated I _p for various loads (Ohms)				I _{ex} µArms	V _{ex} Vrms	Net Weight (grams)	Case Dimensions - mm						
			Ohms	Watt			Nominal	100	500	2K				5K	L	ID	H	W	C	D
AC1005	5	1000:1	100	0.0025	41.80	1.010	0.10	0.46	1.43	2.01	237	0.66	16.3	23.80	9.50	23.80	11.12	15.24	7.62	
AC1010	10	1000:1	100	0.0100	41.80	1.010	0.10	0.45	1.10	1.42	386	1.32	16.3	23.80	9.50	23.80	11.12	15.24	7.62	
AC1015	15	1000:1	100	0.0230	41.80	1.010	0.10	0.45	0.90	1.12	513	1.99	16.3	23.80	9.50	23.80	11.12	15.24	7.62	
AC1020	20	1000:1	100	0.0400	41.80	1.010	0.10	0.43	0.76	0.93	628	2.65	16.3	23.80	9.50	23.80	11.12	15.24	7.62	
AC1025	25	1000:1	100	0.0630	48.00	1.020	0.10	0.47	1.06	1.31	566	3.65	35.5	30.20	11.40	30.20	14.30	20.32	10.16	
AC1030	30	1000:1	100	0.0900	48.00	1.020	0.10	0.47	0.95	1.16	644	4.38	35.5	30.20	11.40	30.20	14.30	20.32	10.16	
AC1040	40	1000:1	100	0.1600	49.3	1.026	0.10	0.46	0.87	1.05	914	5.82	47.3	34.90	14.60	34.90	14.30	25.40	10.16	
AC1050	50	1000:1	100	0.2500	49.3	1.026	0.10	0.43	0.76	0.90	1090	7.28	47.3	34.90	14.60	34.90	14.30	25.40	10.16	
AC1060	60	1000:1	100	0.3600	24.00	1.001	0.10	0.44	0.66	0.76	1250	7.41	65.2	38.10	14.60	38.10	15.90	33.00	10.16	
AC1075	75	1000:1	100	0.5700	24.00	1.001	0.10	0.39	0.57	0.65	1520	9.26	65.2	38.10	14.60	38.10	15.90	33.00	10.16	
AC1100	100	1000:1	100	1.0000	21.30	1.001	0.10	0.34	0.50	0.56	1740	12.00	80.0	44.50	19.05	44.50	14.30	35.56	10.16	
AC1150	150	1000:1	100	2.2500	11.00	1.002	0.10	0.37	0.50	0.55	1820	16.60	150.0	55.60	23.80	55.60	20.60	45.72	12.70	
AC1200	200	1000:1	100	4.0000	11.00	1.002	0.10	0.31	0.41	0.45	2340	22.20	150.0	55.60	23.80	55.60	20.60	45.72	12.70	

I_p: Primary Current
R_t: Terminating Resistor

I_{ex} and V_{ex}: Excitation current & voltage at rated operating conditions
RCF: Ratio correction factor - Multiply current readings by this factor to compensate for transformer losses.

Notes:

- 1) Unless requested, the terminating resistor and the one-turn primary are not supplied
- 2) Pin 3: Normally for mechanical support only but will be used on center tapped designs
- 3) Each part number adjusted to be most accurate at specified load.

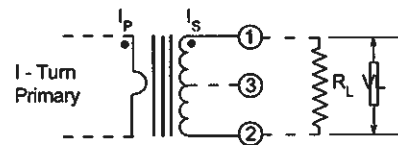
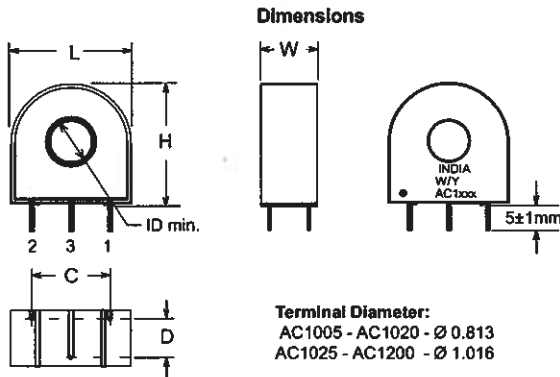

Design and Manufacturing Facilities

<http://www.amveco.com>