

OD9238 VXC High Performance Series

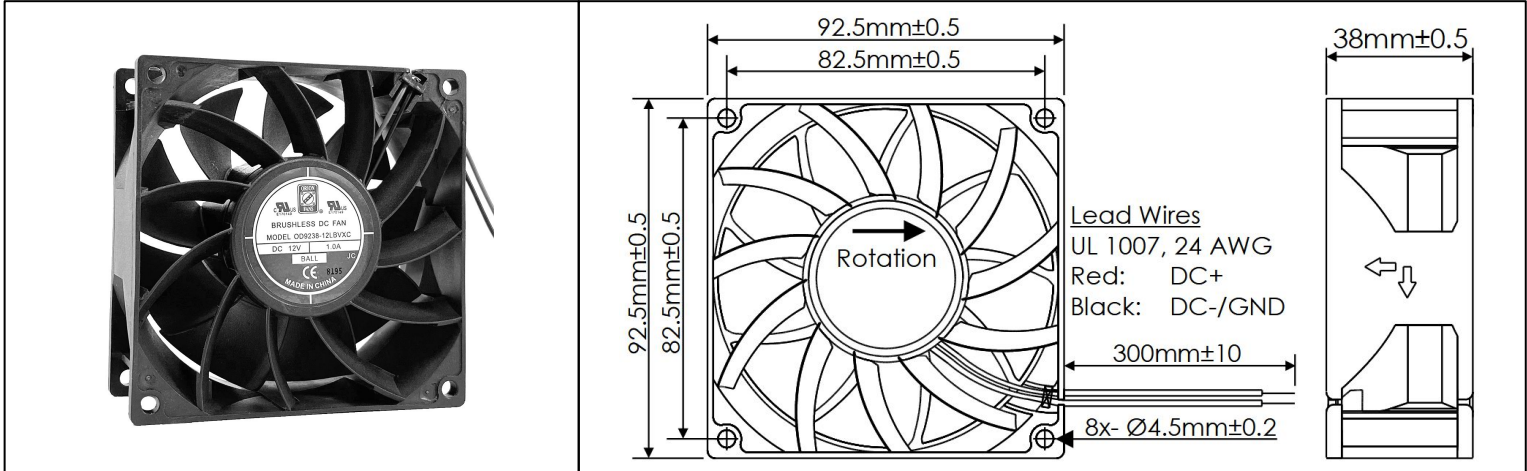

DC Fans - 12, 24, 48V
92.5mm x 38mm (3.64" x 1.5")



Frame	PBT, UL94 V-0 Plastic	<u>Operating Temperature</u> -10°C ~ +70°C <u>Storage Temperature</u> -40°C ~ +80°C <u>Life Expectancy</u> 70,000 Hours (L10 at 40°C) <u>Available Options</u> PWM Speed Control Input Tachometer Output Alarm Output IP Ratings Higher Speeds Weight: 0.47 lbs.	
Impeller	PBT, UL94 V-0 Plastic		
Connection	2x Lead Wires, 24 AWG		
Motor	Brushless DC, Auto Cutoff, Auto Restart, Electronically Protected, Polarity Protected		
Bearing System	Ball Bearings		
Dielectric Strength	500VDC/min, <1mA		
Insulation Resistance	≥10M Ohm @ 500 VDC		

Part Number	Rated Voltage (Volts DC)	Voltage Range (Volts DC)	Input Power (Watts)	Rated Current (Amps)	Rated Speed (RPM)	Max Airflow (CFM)	Noise Level (dBA)	Max Static Pressure ("H ₂ O)
OD9238-12HBVXC	12	8 ~ 13.8	24.0	2.00	5400	125	62	0.74
OD9238-12MBVXC	12	8 ~ 13.8	18.0	1.50	4800	104	58	0.56
OD9238-12LBVXC	12	8 ~ 13.8	12.0	1.00	4400	96	56	0.48
OD9238-24HBVXC	24	22 ~ 25	22.8	0.95	5400	125	62	0.74
OD9238-24MBVXC	24	22 ~ 25	16.8	0.70	4800	105	58	0.56
OD9238-48HBVXC	48	44 ~ 50	21.6	0.45	5400	125	62	0.74

OD9238 VXC Series with PWM and Tach



DC Fans - 12, 24, 48V
92.5mm x 38mm (3.64" x 1.5")

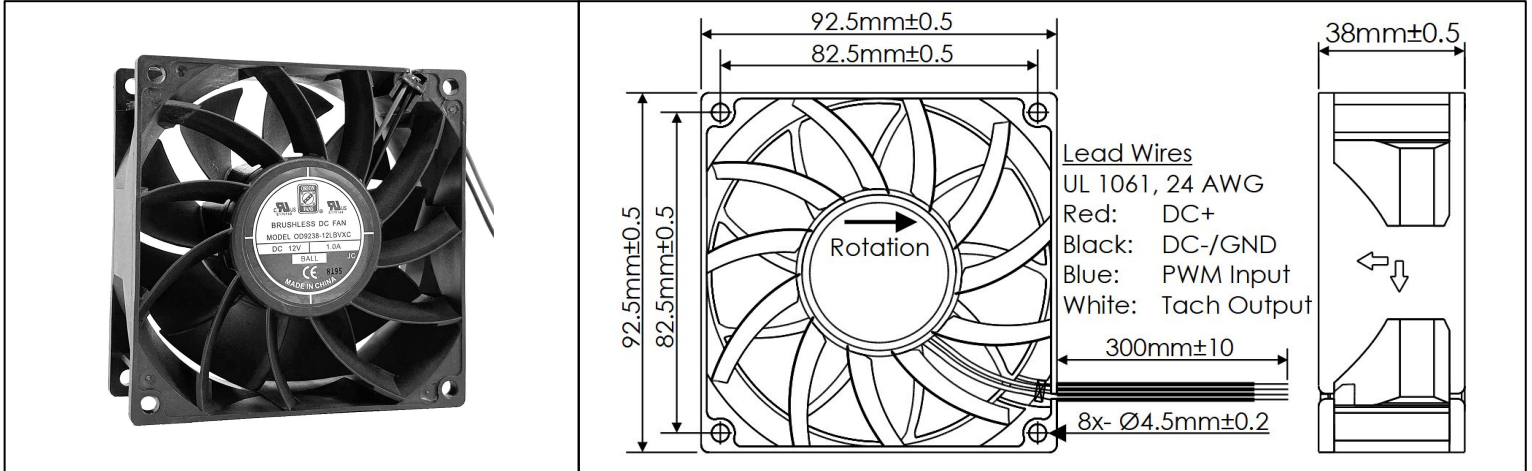

Lead Wires
UL 1061, 24 AWG
Red: DC+
Black: DC-/GND
Blue: PWM Input
White: Tach Output

Frame	PBT, UL94 V-0 Plastic	Operating Temperature -10°C ~ +70°C Storage Temperature -40°C ~ +80°C Life Expectancy 70,000 Hours (L10 at 40°C) Installed Options PWM Speed Control Input Open Collector Tach Output Available Options 5V TTL Tach Output Weight: 0.47 lbs.
Impeller	PBT, UL94 V-0 Plastic	
Connection	4x Lead Wires, 24 AWG	
Motor	Brushless DC, Auto Cutoff, Auto Restart, Electronically Protected, Polarity Protected	
Bearing System	Ball Bearings	
Dielectric Strength	500VDC/min, <1mA	
Insulation Resistance	≥10M Ohm @ 500 VDC	

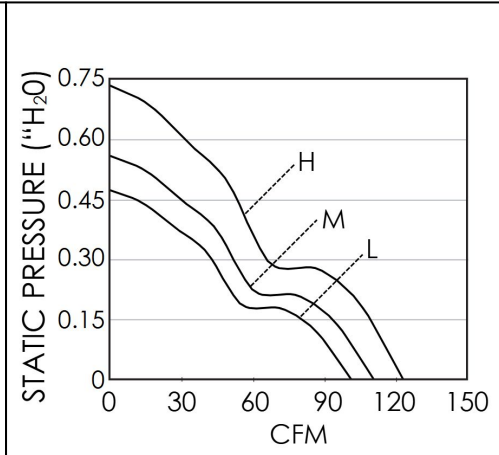

Part Number	Rated Voltage (Volts DC)	Voltage Range (Volts DC)	Input Power (Watts)	Rated Current (Amps)	Rated Speed (RPM)	Max Airflow (CFM)	Noise Level (dBA)	Max Static Pressure ("H ₂ O)
OD9238-12HBVXC10A	12	8 ~ 13.8	24.0	2.00	5400	125	62	0.74
OD9238-12MBVXC10A	12	8 ~ 13.8	18.0	1.50	4800	104	58	0.56
OD9238-12LBVXC10A	12	8 ~ 13.8	12.0	1.00	4400	96	56	0.48
OD9238-24HBVXC10A	24	22 ~ 25	22.8	0.95	5400	125	62	0.74
OD9238-24MBVXC10A	24	22 ~ 25	16.8	0.70	4800	105	58	0.56
OD9238-48HBVXC10A	48	44 ~ 50	21.6	0.45	5400	125	62	0.74

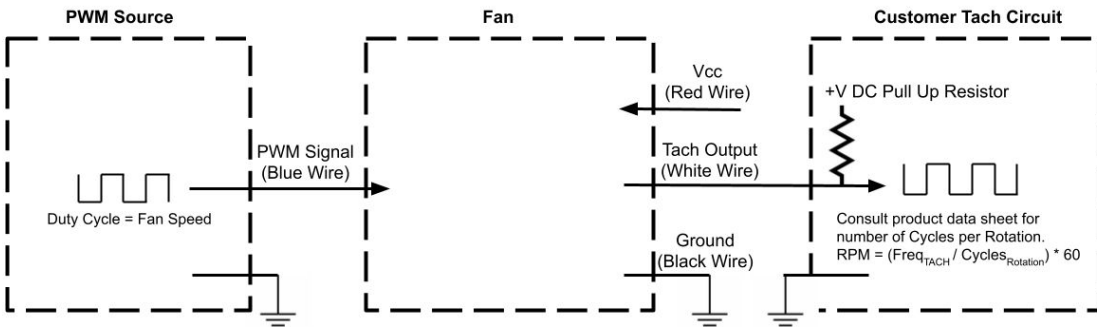

PWM Max High Voltage: 5.5V
PWM Max Sink Current: 5mA
PWM Frequency Range: 18KHz-30KHz
PWM Typical Frequency: 25KHz
RPM at 0% Duty Cycle: 500 RPM±300
 RPM will be full speed if PWM input is disconnected.
Tach Max Pullup Voltage: Fan Vcc
Tach Max Sink Current: 5mA
Tach Cycles per Rotation: 2